



# DIE ACCESSORIES



# CONTENTS

---

	PAGE NUMBER
<b>Gold Bond Fasteners</b>	
Bolts	1
Clamps	3
Nuts	4
Washers	5
<b>Hoist Rings</b>	
Center Pull	6
Side Pull	7
<b>Socket Head Stripper Bolts</b>	
Inch	8
Metric	9
<b>Punch Holder Shanks</b>	10
<b>Roller Stock Guides</b>	11
<b>Stock Pusher</b>	12
<b>Pry Bars</b>	12
<b>Ball Bearing Lubrication</b>	13
<b>Die Lubrication</b>	13

# Gold Bond Fasteners – Bolts

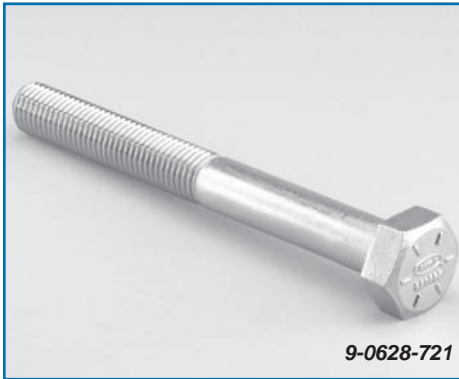

## Product Features

Gold Bond Press Room bolts are forged and utilize heat treated alloy steel. Forging provides extra strength by eliminating the weakness often found at the joint of head and shaft in machined bolts. The alloy steel is heat treated for a minimum tensile strength of 150,000 psi and a hardness of 302-352 BHN (33-39 RC).

Gold Bond bolts conform to or exceed current SAE-J-429 Grade 8 requirements and specifications of SAE-5-123. The threads are National Coarse - Class 2A.

Zinc plating protects against rust and corrosion. The gold finish identifies Gold Bond. These bolts are the superior press room bolt.

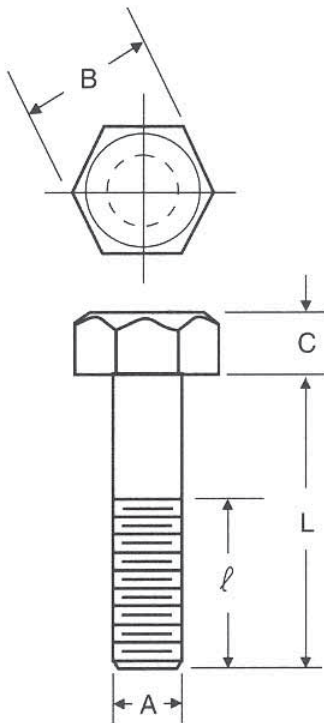

## HEX HEAD BOLTS

Part Number	Thread Size Dia. A (in)	L (in)	B (in)	C (in)	ℓ (in)
9-0612-721	3/4 – 10	3.00	1-1/4	1/2	2.00
9-0614-721		3.50			2.50
9-0616-721		4.00			3.00
9-0618-721		4.50			2.50
9-0620-721		5.00			3.00
9-0624-721		6.00			4.00
9-0628-721		7.00			3.50
9-0632-721		8.00			3.50
9-0640-721		10.00			5.50
9-0812-721		1 – 8			3.00
9-0814-721	3.50		3.00		
9-0816-721	4.00		2.50		
9-0820-721	5.00		2.50		
9-0824-721	6.00		3.50		
9-0826-721	6.50		3.00		
9-0828-721	7.00		3.50		
9-0830-721	7.50		3.50		
9-0832-721	8.00		4.00		
9-0840-721	10.00		5.00		

# Gold Bond Fasteners – Bolts

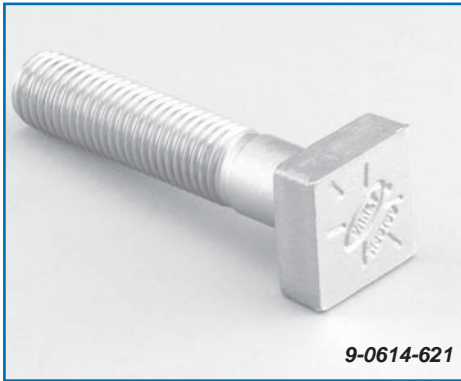

## T-SLOT BOLTS

Part Number	Thread Size Dia. A (in)	L (in)	B (in)	C (in)	ℓ (in)
9-0511-621	5/8 – 11	2.75	1-1/8	13/32	1.75
9-0512-621		3.00			2.00
9-0514-621		3.50			2.50
9-0516-621		4.00			2.50
9-0520-621		5.00			3.50
9-0528-621		7.00			5.50
9-0612-621	3/4 – 10	3.00	1-5/16	17/32	2.00
9-0613-621		3.25			2.25
9-0614-621		3.50			2.50
9-0616-621		4.00			2.50
9-0620-621		5.00			3.50
9-0628-621		7.00			5.50
9-0636-621		9.00			4.50
9-0814-621		1 – 8			3.50
9-0816-621	4.00		3.00		
9-0818-621	4.50		3.50		
9-0820-621	5.00		4.00		
9-0824-621	6.00		4.00		
9-0828-621	7.00		4.00		
9-0832-621	8.00		4.00		
9-0836-621	9.00		4.00		
9-0844-621	11.00		5.00		
9-0852-621	13.00		5.00		
9-0862-621	15.50		5.00		
9-0872-621	18.00		5.00		
9-0882-621	20.50	5.00			

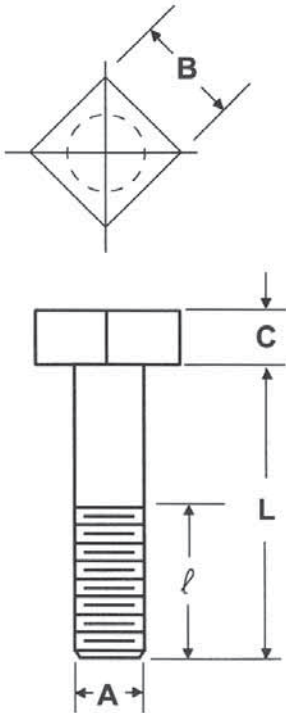

# Gold Bond Fasteners – Clamps

## Product Features

These forged, carbon steel clamps are designed to permit moving the clamping bolt close to the clamped object. The offset construction provides ample room for the slot to pass over the head of the clamping bolt. The clamps are zinc plated for rust resistance and have a gold colored finish.

### OFFSET CLAMPS



MOUNTING ASSEMBLY DRAWING

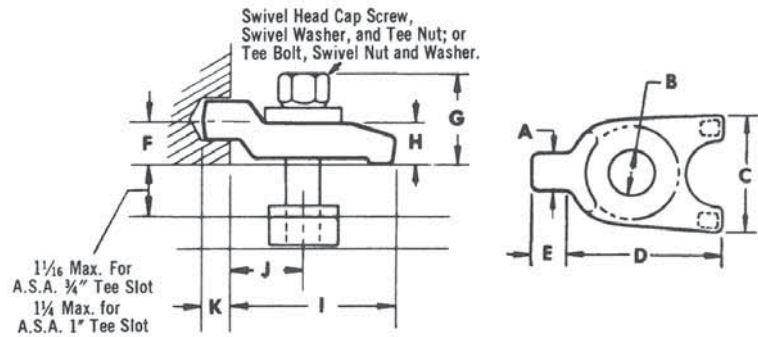

Part Number	Bolt Size (in)	A (in)	B (in)	C (in)	D (in)	E (in)	F (in)	G (in)	H (in)	I (in)	J (in)	K (in)
9-06-301	5/8 or 3/4	3/4	7/8	2-1/4	3	5/8	7/8	1-3/4	13/16	3	1-1/4	5/8
9-07-301	1	3/4	1-1/8	2-1/2	3-5/8	5/8	7/8	2	15/16	3-5/8	1-9/16	5/8

### STRAIGHT CLAMPS

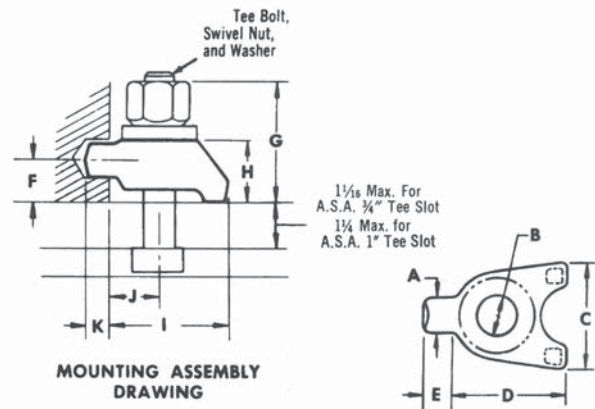

Part Number	Bolt Size (in)	A (in)	B (in)	C (in)	D (in)	E (in)	F (in)	G (in)	H (in)	I (in)	J (in)	K (in)
9-03-301	5/8 or 3/4	3/4	7/8	2-1/4	2-1/2	5/8	7/8	2-3/8	1-5/16	2-1/2	1	5/8
9-04-301	1	3/4	1-1/8	2-3/8	3	5/8	7/8	2-3/4	1-5/16	3	1-1/4	5/8

### GOOSENECK CLAMPS

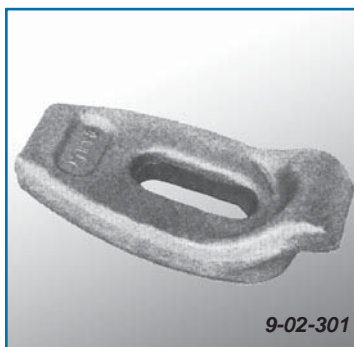

Part Number	Bolt (in)
9-02-301	5/8 or 3/4

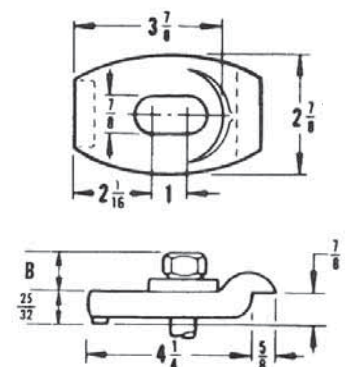

# Gold Bond Fasteners – Nuts

## Product Features

The T-Nuts are manufactured from material meeting SAE Grade 5. In addition, they are hardened to 302-352 BHN (33-39 RC). Sizes conform to ASA standards for use in 3/4" and 1" T-Slots. The hex nuts and swivel nuts are manufactured from heat-treated, high-strength alloy steel and zinc plated for rust and corrosion protection.

### T-NUTS

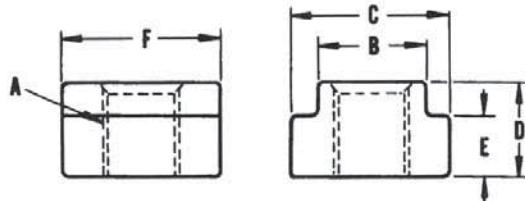

Part Number	Slot Size	A (in)	B (in)	C (in)	D (in)	E (in)	F (in)
9-0511-661	3/4	5/8 – 11	25/32	1-5/16	25/32	17/32	1-5/16
9-0610-661	1	3/4 – 10	1-1/32	1-11/16	1	11/16	1-11/16

### HEX NUTS

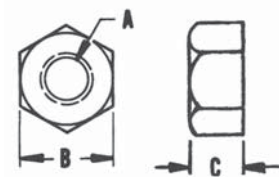

Part Number	Grade	A (in)	B (in)	C (in)
9-0511-681	GRADE 5	5/8 – 11	1-1/16	5/8
9-0610-781	GRADE 8	3/4 – 10	1-1/4	3/4
9-0808-781	GRADE 8	1 – 8	1-5/8	1

### SWIVEL NUTS

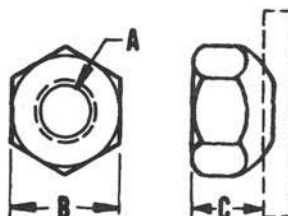
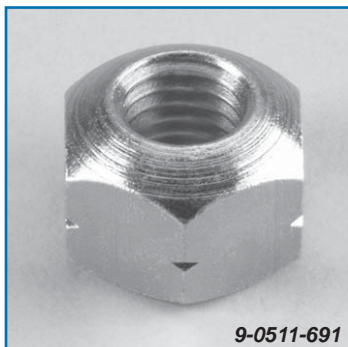

Part Number	A (in)	B (in)	C (in)
9-0511-691	5/8 – 11	1-1/16	11/16
9-0610-691	3/4 – 10	1-1/4	13/16
9-0808-691	1 – 8	1-5/8	1-1/16

# Gold Bond Fasteners – Washers

## Product Features

These washers are manufactured from heat-treated, high strength alloy steel and zinc plated for rust and corrosion protection.

### FLAT WASHERS

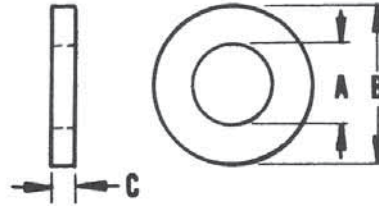

Part Number	Nominal Size	A (in)	B (in)	C (in)
9-0511-711	5/8	11/16	1-1/2	3/16
9-0613-711	3/4	13/16	1-3/4	1/4
9-0817-711	1	1-1/16	2-1/4	5/16

### SWIVEL WASHERS

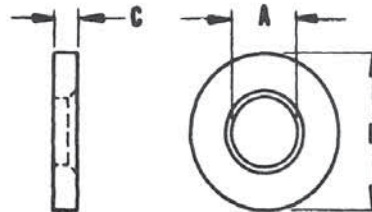

Part Number	Nominal Size	A (in)	B (in)	C (in)
9-01-501	5/8	25/32	1-7/8	5/16
9-02-501	3/4	29/32	1-7/8	3/8
9-05-501	1	1-3/16	2-1/4	3/8

# Hoist Rings – Center Pull



9-0109-88

## Product Features

Center pull hoist rings are manufactured from alloy steel and have a black oxide finish. The clevis bolt, pins, base, washer, bushing, ring and cap screw are magnetic particle inspected.

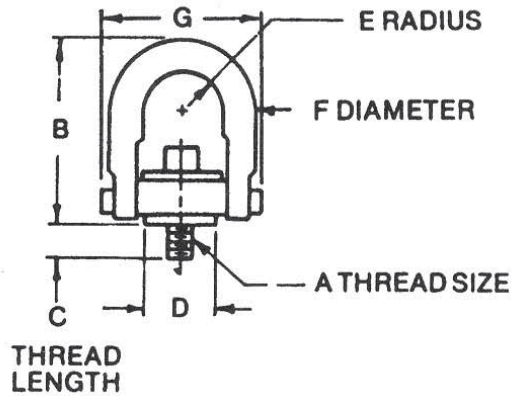

Thread Size A (in)	Load Capacity* (lbs)	STANDARD CLEVIS		LONG CLEVIS		Thread Length C (in)	D (in)	Radius E (in)	Diam. F (in)	G (in)	Torque <sup>1</sup> (lb.ft.)
		Part Number	B (in)	Part Number	B (in)						
5/16 – 18	800	9-0109-88	2.67	–	–	9/16	.75	.43	.38	1.84	7
3/8 – 16	1000	9-0309-88	2.67	–	–	9/16	.75	.43	.38	1.84	12
1/2 – 13	2500	9-0417-88	3.75	–	–	1-1/16	1.20	.69	.50	2.56	28
		9-0412-88	4.78	9-0412-89	6.72	3/4	1.50	.88	.75	3.52	28
		9-0416-88	4.78	9-0416-89	6.72	1	1.50	.88	.75	3.52	28
		9-0420-88	4.78	9-0420-89	6.72	1-1/4	1.50	.88	.75	3.52	28
5/8 – 11	4000	9-0516-88	4.78	9-0516-89	6.72	1	1.50	.88	.75	3.52	60
		9-0520-88	4.78	9-0520-89	6.72	1-1/4	1.50	.88	.75	3.52	60
3/4 – 10	5000	9-0616-88	4.78	9-0616-89	6.72	1	1.50	.88	.75	3.52	100
		9-0624-88	4.78	9-0624-89	6.72	1-1/4	1.50	.88	.75	3.52	100
	7000	9-0616-881	6.52	9-0616-891	8.11	1	2.31	1.40	1.00	5.14	100
		9-0624-881	6.52	9-0624-891	8.11	1-1/2	2.31	1.40	1.00	5.14	100
7/8 – 9	8000	9-0716-88	6.52	9-0716-89	8.11	1	2.31	1.40	1.00	5.14	160
1 – 8	10000	9-0820-88	6.52	9-0820-89	8.11	1-1/4	2.31	1.40	1.00	5.14	230
		9-0824-88	6.52	9-0824-89	8.11	1-1/2	2.31	1.40	1.00	5.14	230
		9-0836-88	6.52	9-0836-89	8.11	2-1/4	2.31	1.40	1.00	5.14	230
1-1/4 – 7	15000	9-1030-88	8.73	–	–	1-7/8	3.19	1.75	1.25	6.50	470
1-1/2 – 6	24000	9-1244-88	12.47	–	–	2-3/4	4.19	2.25	1.75	8.55	800
2 – 4-1/2	30000	9-1650-88	12.47	–	–	3-1/8	4.19	2.25	1.75	8.55	800

<sup>1</sup> Stated load capacity based on specific thread torques as shown in chart. It is recommended that these torques be used when installing hoist rings.

\* Rated at 5:1 strength factor.



# Hoist Rings – Side Pull



## Product Features

Side pull hoist rings are manufactured from alloy steel and have a black oxide finish. The clevis bolt, pins, base, washer, bushing, ring and cap screw are magnetic particle inspected.

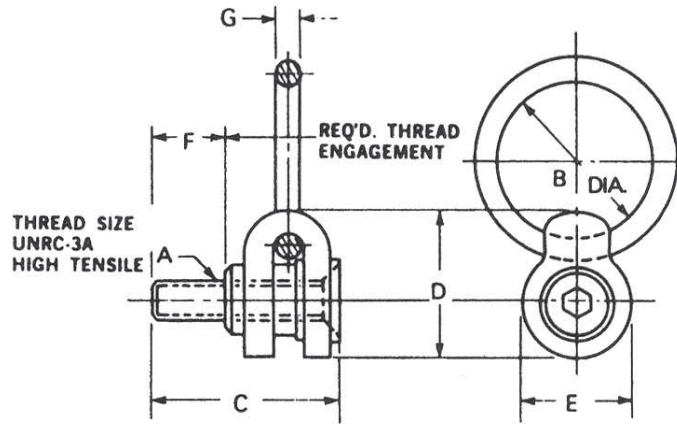

Part Number	Load Capacity*	A (in)	B (in)	C (in)	D (in)	E (in)	F (in)	G (in)	Thread Torque <sup>1</sup>
9-01-87	650	5/16 – 18	2	2-1/8	2	1-1/2	5/8	3/8	3.5
9-03-87	800	3/8 – 16	2	2-3/8	2	1-1/2	3/4	3/8	4.5
9-04-87	1800	1/2 – 13	3	3-3/8	3-3/16	2-3/8	1	5/8	15.0
9-05-87	2500	5/8 – 11	3	3-5/8	3-3/16	2-3/8	1-1/4	5/8	25.0
9-06-87	4100	3/4 – 10	4	5	5	3-3/4	1-1/2	1	50.0
9-08-87	7100	1 – 8	4	5-3/8	5	3-3/4	2	1	90.0
9-10-87	14000	1-1/4 – 7	6	6-7/8	6-13/16	4-5/8	2	1-3/8	150.0
9-12-87	17200	1-1/2 – 6	6	7-7/8	6-13/16	4-5/8	2-1/2	1-3/8	250.0
9-16-87	29000	2 – 4-1/2	5-1/4 x 10-1/2	10	6-13/16	4-5/8	3-1/8	1-1/2	300.0

<sup>1</sup> Stated load capacity based on specific thread torques as shown in chart. It is recommended that these torques be used when installing hoist rings.

\* Rated at 5:1 strength factor.

# Socket Head Stripper Bolts – Inch



## Product Features

Socket head stripper bolts (shoulder screws) are manufactured to close tolerances specifically for tool and die work. They are made from alloy steel that is heat-treated for additional strength. The final product has close tolerances and fully formed threads for the United Class 3A fit.

The knurled heads makes for sure finger grips that allow for fast assembly. The accurate hex socket provides for non-slip internal wrenching.

Part Number	Diam. D (in)	Length L (in)	Thread Pitch	A (in)	C (in)	Part Number	Diam. D (in)	Length L (in)	Thread Pitch	A (in)	C (in)
9-0403-56	1/4	3/8	NC	3/8	#10	9-0824-56	1/2	3	NC	3/4	3/8
9-0404-56		1/2				9-0826-56		3-1/4			
9-0405-56		5/8				9-0828-56		3-1/2			
9-0406-56		3/4				9-0830-56		3-3/4			
9-0408-56		1				9-0832-56		4			
9-0410-56		1-1/4				9-0834-56		4-1/4			
9-0412-56		1-1/2				9-0836-56		4-1/2			
9-0503-56		5/16				3/8		NC			
9-0504-56	1/2		9-0840-56	5							
9-0505-56	5/8		9-1010-56	1-1/4							
9-0506-56	3/4		9-1012-56	1-1/2							
9-0508-56	1		9-1014-56	1-3/4							
9-0510-56	1-1/4		9-1016-56	2							
9-0512-56	1-1/2		9-1018-56	2-1/4							
9-0514-56	1-3/4		9-1020-56	2-1/2							
9-0516-56	2	9-1022-56	2-3/4								
9-0603-56	3/8	3/8	NC	9/16	5/16	9-1024-56	3				
9-0604-56		1/2				9-1026-56	3-1/4				
9-0605-56		5/8				9-1028-56	3-1/2				
9-0606-56		3/4				9-1030-56	3-3/4				
9-0608-56		1				9-1032-56	4				
9-0610-56		1-1/4				9-1034-56	4-1/4				
9-0612-56		1-1/2				9-1036-56	4-1/2				
9-0614-56		1-3/4				9-1038-56	4-3/4				
9-0616-56		2				9-1040-56	5				
9-0618-56		2-1/4				9-1044-56	5-1/2				
9-0620-56		2-1/2				9-1048-56	6				
9-0622-56		2-3/4				9-1212-56	1-1/2				
9-0624-56		3				9-1214-56	1-3/4				
9-0626-56		3-1/4				9-1216-56	2				
9-0628-56		3-1/2				9-1218-56	2-1/4				
9-0630-56		3-3/4				9-1220-56	2-1/2				
9-0632-56	4	9-1222-56	2-3/4								
9-0804-56	1/2	1/2	NC	3/4	3/8	9-1224-56	3				
9-0805-56		5/8				9-1226-56	3-1/4				
9-0806-56		3/4				9-1228-56	3-1/2				
9-0808-56		1				9-1230-56	3-3/4				
9-0810-56		1-1/4				9-1232-56	4				
9-0812-56		1-1/2				9-1234-56	4-1/4				
9-0814-56		1-3/4				9-1236-56	4-1/2				
9-0816-56		2				9-1238-56	4-3/4				
9-0818-56		2-1/4				9-1240-56	5				
9-0820-56		2-1/2				9-1244-56	5-1/2				
9-0822-56		2-3/4				9-1248-56	6				

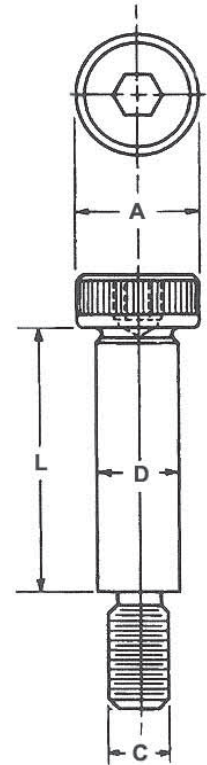

# Socket Head Stripper Bolts – Metric



## Product Features

Socket head stripper bolts (shoulder screws) are manufactured to close tolerances specifically for tool and die work. They are made from alloy steel that is heat-treated for additional strength. The final product has close tolerances and fully formed threads for the United Class 3A fit.

The knurled heads makes for sure finger grips that allow for fast assembly. The accurate hex socket provides for non-slip internal wrenching.

Part Number	Length L (mm)	Diameter D (mm)	Thread Pitch	A (mm)	C (mm)
9-06010-96	10	6	.080	10	M5.0
9-06012-96	12				
9-06016-96	16				
9-06020-96	20				
9-06025-96	25				
9-06030-96	30	8	1.00	13	M6.0
9-08012-96	12				
9-08016-96	16				
9-08020-96	20				
9-08025-96	25				
9-08030-96	30	10	1.25	16	M8.0
9-08040-96	40				
9-08050-96	50				
9-10016-96	16				
9-10020-96	20				
9-10025-96	25	12	1.50	18	M10.0
9-10030-96	30				
9-10040-96	40				
9-10050-96	50				
9-10060-96	60				
9-10070-96	70	16	1.75	24	M12.0
9-10080-96	80				
9-12016-96	16				
9-12020-96	20				
9-12025-96	25				
9-12030-96	30	12	1.50	18	M10.0
9-12040-96	40				
9-12050-96	50				
9-12060-96	60				
9-12070-96	70				
9-12080-96	80	16	1.75	24	M12.0
9-12090-96	90				
9-12100-96	100				
9-16030-96	30				
9-16040-96	40				
9-16050-96	50				
9-16060-96	60				
9-16070-96	70				
9-16080-96	80				
9-16090-96	90				

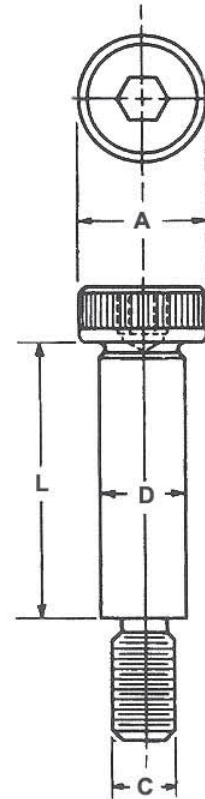

# Punch Holder Shanks



## Product Features

Steel punch shanks are made to dimensions with accurately cut threads for use on any type of die set.

Part Number	Diameter A (in)	Length B (in)	Thread Length C (in)
8-2422-1	1-1/2	2-1/8	1-3/8
8-2424-1			1-1/2
8-2428-1			1-3/4
8-2432-1			2
8-2436-1			2-1/4
8-2440-1			2-1/2
8-2456-1	1-9/16	2-1/8	3-1/2
8-2522-1			1-3/8
8-2524-1			1-1/2
8-2528-1			1-3/4
8-2532-1			2
8-2536-1			2-1/4
8-2540-1	2	2-7/8	2-1/2
8-2556-1			3-1/2
8-3222-1			1-3/8
8-3224-1			1-1/2
8-3228-1			1-3/4
8-3232-1			2
8-3236-1	2-1/2	2-7/8	2-1/4
8-3240-1			2-1/2
8-3256-1			3-1/2
8-4022-1			1-3/8
8-4024-1			1-1/2
8-4028-1			1-3/4
8-4032-1	3	2-7/8	2
8-4036-1			2-1/4
8-4040-1			2-1/2
8-4056-1			3-1/2
8-4822-1			1-3/8
8-4824-1			1-1/2
8-4828-1	2-7/8	2-7/8	1-3/4
8-4832-1			2
8-4836-1			2-1/4
8-4840-1			2-1/2
8-4856-1			3-1/2

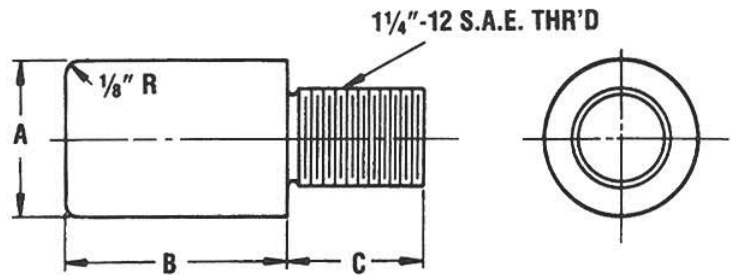

# Roller Stock Guides



## Product Features

The roller stock guides provide for accurate guiding of strip and coil stock. This product is designed to withstand hard wear and vibration. All posts are made of steel and the rollers, arms, collar and brackets are hardened.

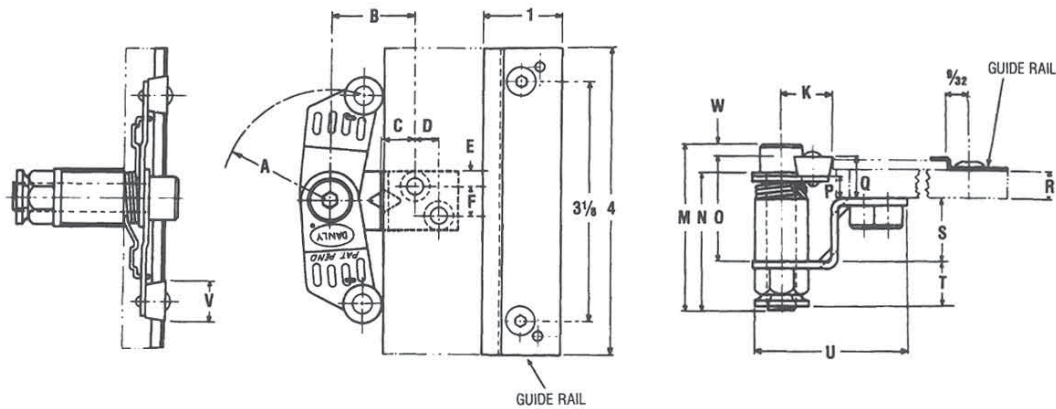

Part Number	Roller Guide	A (in)	B (in)	C (in)	D (in)	E (in)	F (in)	K (in)	M (in)	N (in)
9-70-6	Large	2	1-15/32	5/8	1/4	5/16	7/16	7/8 min.	3-1/4	2-3/4
9-60-6	Small	1-3/8	1-1/16	7/16	5/16	3/16	3/8	5/8 min.	2-1/8	1-3/4

Part Number	Roller Guide	O (in)	P (in)	Q (in)	R (in)	S (in)	T (in)	U (in)	V (in)	W (in)
9-70-6	Large	1.836	.244	.617	3/8 *	1-7/32	19/32	2-3/4	3/4	.164
9-60-6	Small	1.351	.292	.538	3/8 *	13/16	15/32	2	1/2	.164

\* If platform thickness is other than 3/8", certain easily-made mounting adjustments are necessary. These adjustments are covered in the mounting instructions included in each box.

# Stock Pusher



9-90-6

## Product Features

These stock pushers mount on the front, rear or sides of a die set to best suit die and feed. Both sizes of stock pushers are supplied with three different length wedges, allowing the diemaker to select the best wedge for a particular shut height.

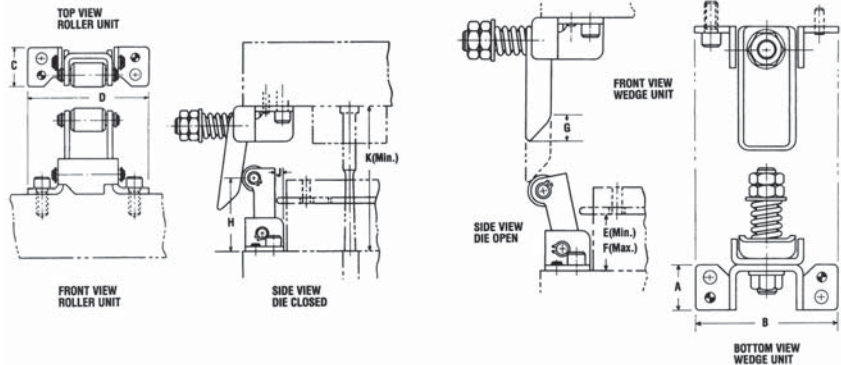

Part Number	A (in)	B (in)	C (in)	D Min. (in)	E Max. (in)	F (in)	G (in)	H (in)	J Min. (in)	K (in)	Wedge Lengths (in)	Spring Rate
9-90-6	7/8	2-13/16	7/8	2-13/16	7/8	1-3/4	5/8	1-11/16	1/8	3	2-3/8,* 2-7/8, 3-3/8	300 lb/in
9-95-6	1-3/8	3-3/8	1-1/4	3-3/8	1-1/4	2-1/4	1-1/8	2	3/16	4	3-13/16,* 4-5/16, 4-13/16	1630 lb/in

Screws, dowels and mounting instructions are included in package with each Stock Pusher.

\* Shortest wedge length is assembled into unit; other wedges are included in package.

# Pry Bars



9-04-15 with shoe

## Product Features

This forged steel pry bar, with a black oxide finish, is a practical tool for use in separating punch and die holders without damage to the die.

With its soft tempered brass shoe and bronze alloy tip, the pry bar easily separates the die without harming surfaces. Both shoe and tip are easily removable and replaceable.

Overall length is 18-1/4".

Part Number	Description
9-01-15	Pry Bar, as forged
9-04-15	Pry Bar with tip and shoe
9-05-15	Tip & Shoe Package (2 tips, 2 shoes, screws & nuts)
9-06-15	Tip Package (6 tips, screws & nuts)

# Ball Bearing Lubrication



*Component maintenance is serious business... Always use Ball-Lube® and Ball-Scrubb® to keep ball-bearing components clean and running smooth.*

## Product Features

**BALL-SCRUBB®** removes heavy soils, dirt or grease from ball-bearing guide pin assemblies. Just spray it on... wait three minutes... and spray again. Then blow off excess with compressed air. **BALL-SCRUBB®** is an industrial strength cleaner with rust inhibitors, specially formulated to clean debris and grease from all types of ball-bearing assemblies.

**BALL-LUBE®**, when applied after **BALL-SCRUBB®**, locks out wear by chemically bonding to precision surfaces. It provides a tough, long-lasting shield that protects against oxidation and rust. **BALL-LUBE®** lubricates assemblies and gives them longtime protection against wear, oxidation and heat. Spray liberally on ball-bearing assemblies.

Part Number	BALL-LUBE® Size
ARL016	Pint BALL-LUBE® spray
ARL384	Case (24) 1 Pint BALL-LUBE®
ARL128	Gallon BALL-LUBE®
ARL640	Gallons BALL-LUBE®

Part Number	BALL-SCRUBB® Size
ARS016	1 Pint BALL-SCRUBB® Spray
ARS384	1 Case (24) 1 Pint BALL-SCRUBB®
ARS128	1 Gallon BALL-SCRUBB®
ARS640	5 Gallons BALL-SCRUBB®

# Die Lubrication



## Product Features

This die lubricant is specially prepared to provide efficient lubrication for guide posts in plain bearing applications.

Part Number	Size
9-01-52	1 Quart
9-02-52	1 Gallon
9-02-521	55 Gallons
9-02-522	15 Gallons

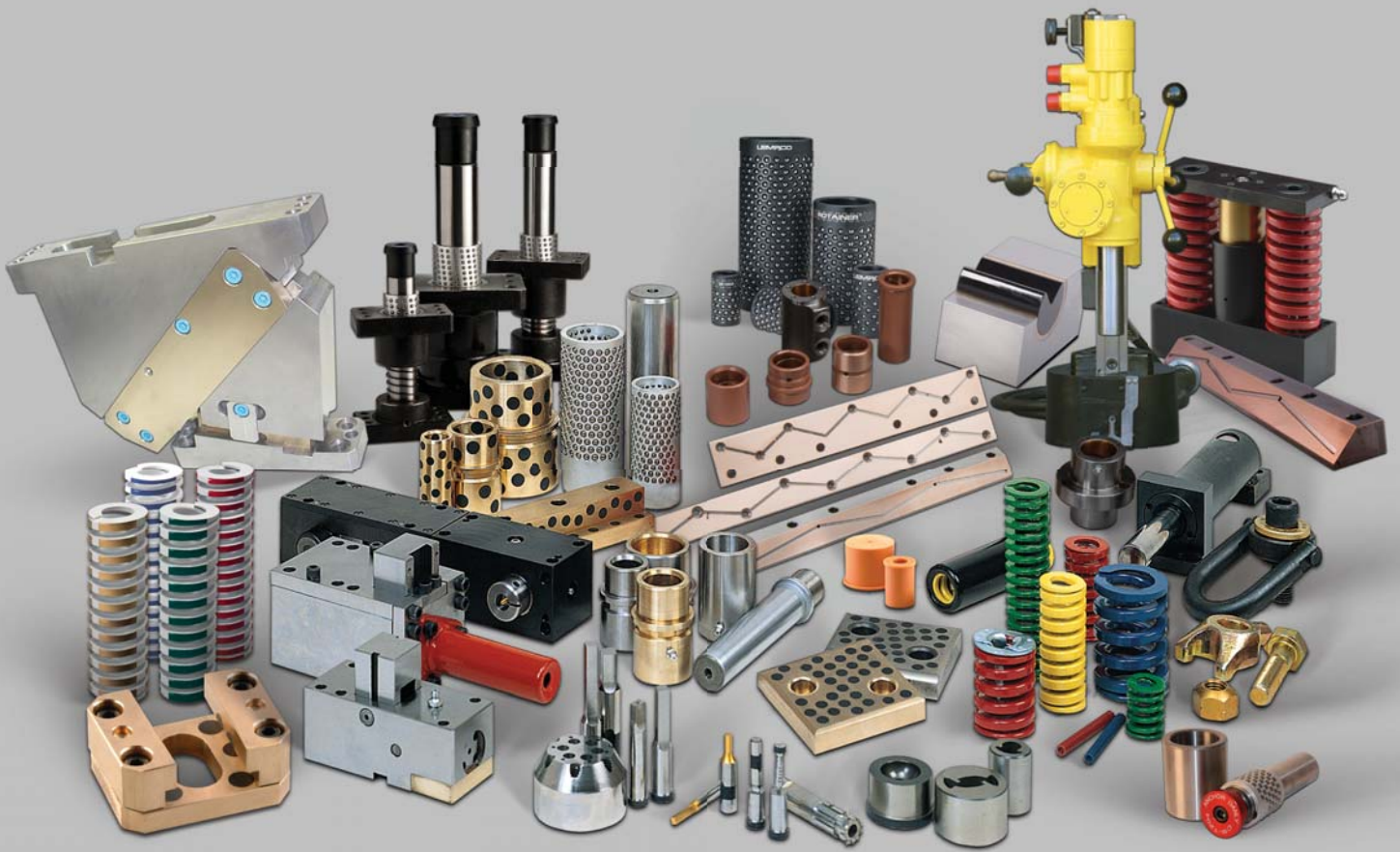

## DIE ACCESSORIES CATALOG

# IEM<sup>®</sup>

Distributed by:

[www.danly.com](http://www.danly.com)  
[info@anchorlamina.com](mailto:info@anchorlamina.com)

**WITHIN THE USA & CANADA**

**CALL: 800-652-6462**

**FAX: 800-406-4410**

**OUTSIDE THE USA & CANADA**

**CALL: 248-489-7816**

**FAX: 248-553-6842**



Registered  
to ISO 9001

Registered  
to ISO 14001