



## Round Die Products

## BUSHINGS

General Information — Bushings ..... 2 & 3

### STANDARD SHOULDER BUSHINGS

Bronze Plated & Solid Steel..... 4

Solid Bronze & Self-Lubricating..... 5

Press Fit ..... 6

Bushings for Lifter Pin – Metric ..... 6

Long & Extra Long Shoulder Bushings ..... 7

### SHORT SHOULDER BUSHINGS

Bronze Plated..... 8

Solid Bronze..... 9

Self-Lubricating ..... 10

### METRIC BUSHINGS

NAAMS ..... 11 & 12

Standard Shoulder Bushings – Metric ..... 13

Long & Extra Long

Shoulder Bushings – Metric..... 14

Short Shoulder Bushings Metric..... 15

## TECHNICAL INFORMATION

Toe Clamp Selection ..... 16

Toe Clamp Placement ..... 17

Bore Sizes for Pins & Bushings..... 18

## MISCELLANEOUS BUSHINGS

Running Fit Bushings – Hardened ..... 19

Running Fit Bushings – Soft ..... 20

Guide Bar Bushings (Wiper Bushings) ..... 21

Precision Bearings ..... 21

## GUIDE PINS

General Information – Pins..... 22

Straight Guide Pins TN & ATN ..... 23

Straight Guide Pins TPB ..... 24

Straight Guide Pins TPC ..... 25

Straight Guide Pins NAAMS ..... 26

Straight Guide Pins Hollow ..... 26

Straight Guide Pins TN Metric..... 27

Straight Guide Pins TPB Metric ..... 27

## GUIDE PINS, *continued*

Guide Pins – Tap Fit (Demountable)..... 28 & 29

Guide Pins – Shoulder

Inch ..... 30

Metric..... 31

Guide Pins – Removable..... 32

Stripper Guide Pins & Bushings ..... 34 & 35

## STOCK LIFTERS

75 Stock Lifters..... 36

112 Stock Lifters ..... 37

75 Rail Lifters ..... 38

112 Rail Lifters ..... 39

Mini Lifters ..... 40

Repair Parts ..... 41

Metric Lifter Pins ..... 42

Stop Blocks..... 43

## PAD RETAINERS

Pad Retainers, Standard – Inch..... 44

Pad Retainers, Reverse Mount – Inch ..... 45

Pad Retainers, Standard & Reverse – Metric.. 46

Spool Type Pad Retainers – Metric..... 47



## SHOULDER BUSHING STYLES

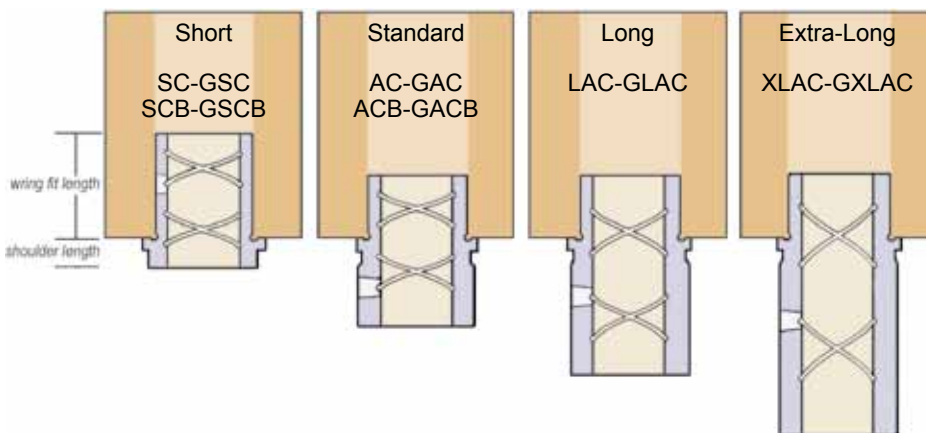

All bronze plated shoulder bushings must be wring-fit in the die shoe. It is also recommended that Solid Bronze shoulder bushings be mounted similarly.

Bronze plated bushings feature figure 8 oil grooves for maximum lubrication. For long wear, bronze plated bushings should be lubricated with a high temperature, high pressure lithium grease on a regular basis.

Self-lubricating bronze with graphite bushings require initial lubrication with light oil. Periodic lubrication will extend the life of self-lubricating bushings. **DO NOT USE GREASE.**

Specials have become very important at Lamina. The table below will give a basic idea of our everyday manufacturing capabilities. If you have a need for special bushings, please send your requests for quotations. See page 22 for pin manufacturing capabilities.

BUSHING MANUFACTURING CAPABILITIES						
	Series Inch	Min. Length	Max. Length	Series Metric	Min. Length	Max. Length
Straight & Shoulder	0.750	1	2.0	32	25	150
	1.000	1	3.0	40	25	150
	1.250	1	6.0	50	25	350
	1.500	1	6.0	63	25	350
	1.750	1	10.0	80	25	350
	2.000	1	14.0	100	25	350
	2.500	1	14.0	125	25	350
	3.000	1	14.0	.	.	.
Bronze Plated & Solid Steel	0.625	1	2.0	.	.	.
	0.750	1	3.0	19	25	100
	0.875	1	4.0	.	.	.
	1.000	1	5.0	.	.	.
	1.250	1	7.0	.	.	.
	1.500	1	7.0	.	.	.
	1.750	1	7.0	40	25	150
	2.000	1	9.0	50	25	225
	2.500	1	9.0	63	25	225
	3.000	1	9.0	80	25	225
Solid Bronze	0.500	0.375	5.0	.	.	.
	0.625	0.375	5.87	12.5	9	50
	0.750	0.375	5.87	.	.	.
	0.875	0.375	5.87	20	9	140
	1.000	0.375	5.87	.	.	.
	1.250	1	6.0	.	.	.
	1.500	1	6.0	.	.	.
	1.750	1	6.0	40	9	150
	2.000	1	6.0	.	.	.
	2.500	1.25	8.0	.	.	.
	3.000	1.25	8.0	.	.	.
	3.750	2	16.0	.	.	.
	4.500	2	16.0	100	50	400
Self-Lubricating	0.625	0.375	3.5	12.5	9	50
	0.750	0.875	6.0	19	9	140
	0.875	0.875	6.0	20	9	140
	1.000	0.875	6.0	.	.	.
	1.250	0.875	6.0	.	.	.
	1.500	0.875	6.0	.	.	.
	1.750	0.875	6.0	.	.	.
	2.000	1.25	6.0	.	.	.
	2.500	1.25	8.0	63	25	200
	3.000	1.25	8.0	.	.	.
	3.750	1.25	8.0	.	.	.
	4.500	1.25	8.0	125	50	200

We are not restricted to the above parameters. Every quote will be analyzed for manufacturing possibility.

## LAMINA DIE SET STANDARD GRIND (LDSS)

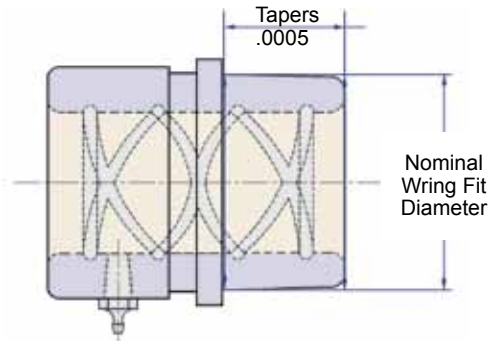

Slight taper on wring fit diameter facilitates installation. (This feature is standard on all bronze plated and solid steel shoulder bushings unless otherwise noted.) Bushings are held in place with toe clamps and screws unless otherwise noted.

In the following pages bronze plated and solid steel bushings which are listed as ground are "LDSS" ground.

## GUIDE BUSHINGS

Class 1 & 2 bushing dimensions shown opposite are for use in precision die sets.

Class 3 bushings are for use with automotive, hardware, forming or draw dies where stamping stock is thicker than 1/16", and clearances between punch and die sections will be more than .003" per side.

■ Bronze-Plated Bushings Available in Class 1 or Class 2

■ Solid Bronze Bushings Available in Class 1 or Class 2

■ Hardened Steel Bushings available in Class 2

■ Self-Lubricating Bushings available in Class 3

D1 NOMINAL PIN DIAMETER	LAMINA BUSHINGS I.D. Dimensions		
	Class 1	Class 2	Class 3
3/4	<u>.7503</u> .7502	<u>.7506</u> .7503	<u>.7510</u> .7506
7/8	<u>.8753</u> .8752	<u>.8756</u> .8753	<u>.8760</u> .8756
1	<u>1.0003</u> 1.0002	<u>1.0006</u> 1.0003	<u>1.0010</u> 1.0006
1-1/4	<u>1.2503</u> 1.2502	<u>1.2506</u> 1.2503	<u>1.2510</u> 1.2506
1-1/2	<u>1.5003</u> 1.5002	<u>1.5006</u> 1.5003	<u>1.5010</u> 1.5006
1-3/4	<u>1.7503</u> 1.7502	<u>1.7506</u> 1.7503	<u>1.7512</u> 1.7507
2	<u>2.0003</u> 2.0002	<u>2.0007</u> 2.0003	<u>2.0012</u> 2.0007
2-1/2	<u>2.5006</u> 2.5004	<u>2.5012</u> 2.5006	<u>2.5018</u> 2.5012
3	<u>3.0008</u> 3.0006	<u>3.0014</u> 3.0008	<u>3.0023</u> 3.0014
3-3/4	—	<u>3.7518</u> 3.7510	<u>3.7528</u> 3.7518
4-1/2	—	<u>4.5025</u> 4.5015	<u>4.5035</u> 4.5025

# Bushings – Inch – Wring Fit Style



**BRONZE PLATED**



**SOLID STEEL**

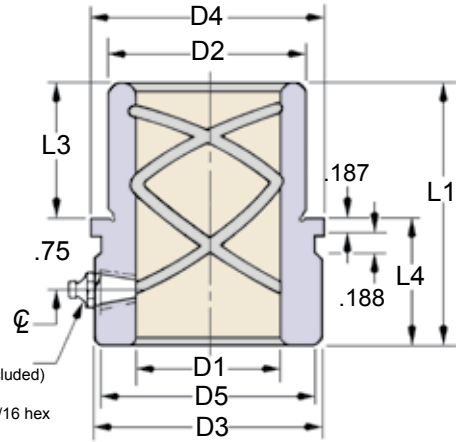

Grease Fitting (included)  
 Ø3/4" - 1/4-28, 5/16 hex  
 Ø7/8 - 3" - 1/8-27 NPTF, 7/16 hex

\*See page 3 for details.

See pages 16 & 17 for toe clamp installation instructions.

D-Clamps & Screws are included with wring fit style bushings.

## STANDARD SHOULDER BUSHINGS – BRONZE PLATED

PART NUMBER Class 2*		PART NUMBER Class 1*		D1 Nom Pin Diam.	D2 Wring Fit Diameter		D3 Head OD	D4 Shoulder OD	D5 Head OD Groove	L1 Overall Length	L3 Wring Fit Length	L4 Head Length
GROUND	UNGROUND	GROUND	UNGROUND		GROUND	UNGROUND						
GAC-750-S	AC-750-S	GAC7501S	AC7501S	3/4	1.1250	1.140	1.219	1.313	1.125	2.063	0.813	1.250
GAC-875-S	AC-875-S	GAC8751S	AC8751S	7/8	1.3750	1.390	1.469	1.563	1.375	2.125	0.875	1.250
GAC-100-S	AC-100-S	GAC1001S	AC1001S	1	1.5000	1.515	1.656	1.750	1.563	2.125	0.875	1.250
GAC-100-L	AC-100-L	GAC1001L	AC1001L							3.125	1.875	
GAC-125-S	AC-125-S	GAC1251S	AC1251S	1-1/4	1.7500	1.765	2.031	2.125	1.938	2.625	1.125	1.500
GAC-125-L	AC-125-L	GAC1251L	AC1251L							3.625	2.125	
GAC-150-SP	N/A	N/A	N/A	1-1/2	2.0000	N/A	2.281	2.375	2.188	2.650	1.150	1.500
GAC-150-S	AC-150-S	GAC1501S	AC1501S			2.015				2.875	1.375	
GAC-150-L	AC-150-L	GAC1501L	AC1501L			3.875				2.375		
GAC-175-SP	N/A	N/A	N/A	1-3/4	2.2500	N/A	2.531	2.625	2.438	2.875	1.375	1.500
GAC-175-S	AC-175-S	GAC1751S	AC1751S			2.265				3.125	1.625	
GAC-175-L	AC-175-L	GAC1751L	AC1751L			4.125				2.625		
GAC-200-SP	N/A	N/A	N/A	2	2.5000	N/A	3.031	3.125	2.938	2.875	1.375	1.500
GAC-200-S	AC-200-S	GAC2001S	AC2001S			2.515				3.375	1.875	
GAC-200-L	AC-200-L	GAC2001L	AC2001L			4.375				2.875		
GAC-250-S	AC-250-S	GAC2501S	AC2501S	2-1/2	3.0000	3.015	3.531	3.625	3.438	3.875	1.875	2.000
GAC-300-S	AC-300-S	GAC3001S	AC3001S	3	3.6250	3.640	4.281	4.375	4.188	3.875	1.875	2.000

## STANDARD SHOULDER BUSHINGS – SOLID STEEL

PART NUMBER Class 2 only*		D1 Nom Pin Diam.	D2 Wring Fit Diameter		D3 Head OD	D4 Shoulder OD	D5 Head OD Groove	L1 Overall Length	L3 Wring Fit Length	L4 Head Length
GROUND	UNGROUND		GROUND	UNGROUND						
GAC-750-SS	AC-750-SS	3/4	1.1250	1.140	1.219	1.313	1.125	2.063	0.813	1.250
GAC-100-SS	AC-100-SS	1	1.5000	1.515	1.656	1.750	1.563	2.125	0.875	1.250
GAC-100-SS2	AC-100-SS2							2.875		2.000
GAC-125-SS	AC-125-SS	1-1/4	1.7500	1.765	2.031	2.125	1.938	2.625	1.125	1.500
GAC-125-SS2	AC-125-SS2							3.125		2.000
GAC-150-SS	AC-150-SS	1-1/2	2.0000	2.015	2.281	2.375	2.188	2.875	1.375	1.500
GAC-150-SS2	AC-150-SS2							3.375		2.000
GAC-175-SS	AC-175-SS	1-3/4	2.2500	2.265	2.531	2.625	2.438	3.125	1.625	1.500
GAC-175-SS2	AC-175-SS2							3.625		2.000
GAC-200-SS	AC-200-SS	2	2.5000	2.515	3.031	3.125	2.938	3.375	1.875	1.500
GAC-200-SS2	AC-200-SS2							3.875		2.000
GAC-250-SS	AC-250-SS	2-1/2	3.0000	3.015	3.531	3.625	3.438	3.875	1.875	2.000

## Bushings – Inch – Wring Fit Style



**SOLID BRONZE**



**SELF-LUBRICATING**

Grease Fitting (Solid Bronze only)  
Grease Fittings  
Ø3/4 - 1/4-28, 5/16 hex  
Ø7/8 - 3" - 1/8-27 NPTF, 7/16 hex

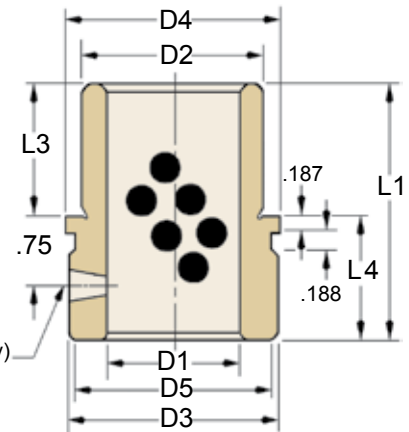

\*See page 3 for details.

See pages 16 & 17 for toe clamp installation instructions.

D-Clamps & Screws are included with wring fit style bushings.

STANDARD SHOULDER BUSHINGS – SOLID BRONZE												
PART NUMBER Class 2*		PART NUMBER Class 1*		D1 Nom Pin Diam.	D2 Wring Fit Diameter		D3 Head OD	D4 Shoulder OD	D5 Head OD Groove	L1 Overall Length	L3 Wring Fit Length	L4 Head Length
GROUND	UNGROUND	GROUND	UNGROUND		GROUND	UNGROUND						
GAC-750-SB	AC-750-SB	GAC7501SB	AC7501SB	3/4	1.1250	1.140	1.219	1.313	1.125	2.063	0.813	1.250
GAC-875-SB	AC-875-SB	GAC8751SB	AC8751SB	7/8	1.3750	1.390	1.469	1.563	1.375	2.125	0.875	1.250
GAC-100-SB	AC-100-SB	GAC1001SB	AC1001SB	1	1.5000	1.515	1.656	1.750	1.563	2.125	0.875	1.250
GAC-125-SB	AC-125-SB	GAC1251SB	AC1251SB	1-1/4	1.7500	1.765	2.031	2.125	1.938	2.625	1.125	1.500
GAC-150-SB	AC-150-SB	GAC1501SB	AC1501SB	1-1/2	2.0000	2.015	2.281	2.375	2.188	2.875	1.375	1.500
GAC-175-SB	AC-175-SB	GAC1751SB	AC1751SB	1-3/4	2.2500	2.265	2.531	2.625	2.438	3.125	1.625	1.500
GAC-200-SB	AC-200-SB	GAC2001SB	AC2001SB	2	2.5000	2.515	3.031	3.125	2.938	3.375	1.875	1.500
GAC-250-SB	AC-250-SB	GAC2501SB	AC2501SB	2-1/2	3.0000	3.015	3.531	3.625	3.438	3.875	1.875	2.000
GAC-300-SB	AC-300-SB	GAC3001SB	AC3001SB	3	3.6250	3.640	4.281	4.375	4.188	3.875	1.875	2.000

STANDARD SHOULDER BUSHINGS – SELF-LUBRICATING										
PART NUMBER Class 3 only*		D1 Nom. Pin Diam.	D2 Wring Fit Diameter		D3 Head OD	D4 Shoulder OD	D5 Head OD Groove	L1 Overall Length	L3 Wring Fit Length	L4 Head Length
GROUND	UNGROUND		GROUND	UNGROUND						
GACB750S	ACB750S	3/4	1.1250	1.140	1.219	1.313	1.125	2.063	0.813	1.250
GACB100S	ACB100S	1	1.5000	1.515	1.656	1.750	1.563	2.125	0.875	1.250
GACB125S	ACB125S	1-1/4	1.7500	1.765	2.031	2.125	1.938	2.625	1.125	1.500
GACB150S	ACB150S	1-1/2	2.0000	2.015	2.281	2.375	2.188	2.875	1.375	1.500
GACB175S	ACB175S	1-3/4	2.2500	2.265	2.531	2.625	2.438	3.125	1.625	1.500
GACB200S	ACB200S	2	2.5000	2.515	3.031	3.125	2.938	3.375	1.875	1.500
GACB250S	ACB250S	2-1/2	3.0000	3.015	3.531	3.625	3.438	3.875	1.875	2.000
GACB300S	ACB300S	3	3.6250	3.640	4.281	4.375	4.188	3.875	1.875	2.000

**Note:** Self-lubricating bronze with graphite bushings require initial lubrication with light oil. Periodic lubrication will extend the life of self-lubricating bushings. **DO NOT USE GREASE.**

All Standard Shoulder Bushings (**unless otherwise noted**) are to be wring fit and held in place with toe clamps and screws. This means that the bushing should be installed into the die shoe using a wringing (**circular**) motion with the heel of the hand. **Please see bore size information on page 18.**

## Bushings – Inch – Press Fit Style

Press Fit Shoulder Bushings allow for fast, easy installation. Eliminates the use of clamps and screws.



**BRONZE PLATED**

Figure 8 oil grooves allow the lubricant to flow smoothly throughout the bushing I.D.

Grease Fittings  
3/4 - 1/4-28, 5/16 hex  
7/8 -3" - 1/8-27 NPTF, 7/16 hex

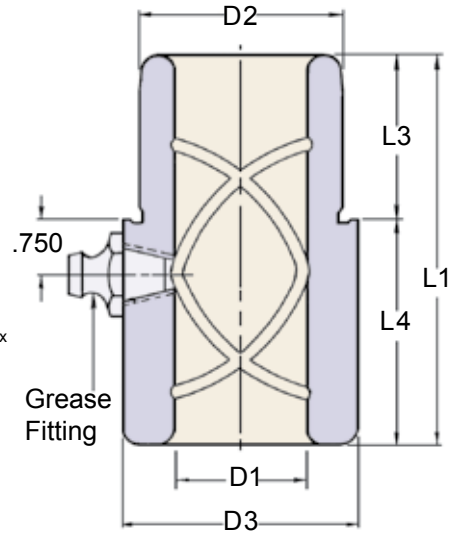

SHOULDER BUSHING – PRESS FIT								
PART NUMBER	NOM. PIN DIAMETER	D1*	D2 PRESS FIT DIAMETER	D3 HEAD O.D.	L1 OVERALL LENGTH	L4 HEAD LENGTH	L3 PRESS FIT LENGTH	REC'D BORE SIZE
8-1188-2500	1	1.0006	1.5023	1.688	2.500	1.313	1.188	1.5005
		1.0003	1.5018					1.5000
10-1188-2688	1-1/4	1.2506	1.7523	1.938	2.688	1.500	1.188	1.7505
		1.2503	1.7518					1.7500
12-1438-2938	1-1/2	1.5007	2.0023	2.188	2.938	1.500	1.438	2.0005
		1.5004	2.0018					2.0000

**\*Please note!**

**Press Fit bushings have tapered holes, larger at press fit end. This facilitates honing, since the bore will close up in a more nearly straight line when pressed in.**

While these bushings are precision finished on the O.D. a small amount of stock is left on the I.D. to allow for honing because they are press fit type.

Toe clamps and screws are not provided with press fit shoulder bushings and they do not come with an LDSS grind.

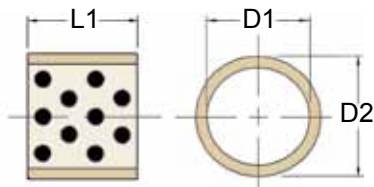

BUSHINGS FOR LIFTER PINS –METRIC			
PART NUMBER	D1	D2	L1
MBL-704530	45	55	30
MBL-704540			40
MBL-704550			50

# Bushings – Wring Fit Style



**BRONZE PLATED**



**SOLID STEEL**

D-Clamps & Screws are included with wring fit style bushings.

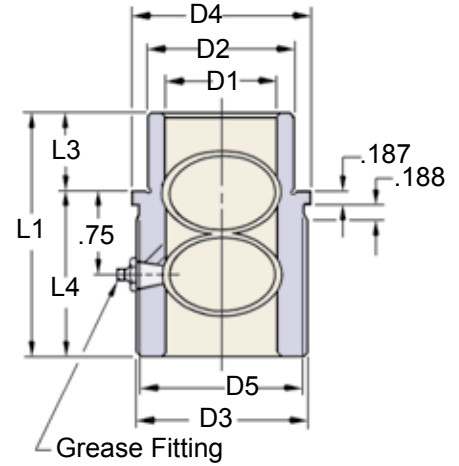

Grease Fittings  
 Ø3/4 - 1/4-28, 5/16 hex  
 Ø7/8 -3" - 1/8-27 NPTF, 7/16 hex

\*See page 3 for details.  
 See pages 16 & 17 for toe clamp placement instructions.

LONG SHOULDER BUSHINGS – BRONZE PLATED												
PART NUMBER Class 2*		PART NUMBER Class 1*		D1 Nom Pin Diam.	D2 Wring Fit Diameter		D3 Head OD	D4 Shoulder OD	D5 Head OD Groove	L1 Overall Length	L3 Wring Fit Length	L4 Head Length
GROUND	UNGROUND	GROUND	UNGROUND		GROUND	UNGROUND						
GLAC-750-S	LAC-750-S	GLAC7501S	LAC7501S	3/4	1.1250	1.140	1.219	1.313	1.125	2.813	0.813	2.000
GLAC-875-S	LAC-875-S	GLAC8751S	LAC8751S	7/8	1.3750	1.390	1.469	1.563	1.375	3.000	0.875	2.125
GLAC-100-S	LAC-100-S	GLAC1001S	LAC1001S	1	1.5000	1.515	1.656	1.750	1.563	3.125	0.875	2.250
GLAC-125-S	LAC-125-S	GLAC1251S	LAC1251S	1-1/4	1.7500	1.765	2.031	2.125	1.938	3.500	1.125	2.375
GLAC-150-S	LAC-150-S	GLAC1501S	LAC1501S	1-1/2	2.0000	2.015	2.281	2.375	2.188	4.125	1.375	2.750
GLAC-150-SP	N/A	N/A	N/A	1-1/2	2.0000	2.015	2.281	2.375	2.188	3.900	1.150	2.750
GLAC-175-S	LAC-175-S	GLAC1751S	LAC1751S	1-3/4	2.2500	2.265	2.531	2.625	2.438	4.625	1.625	3.000
GLAC-200-S	LAC-200-S	GLAC2001S	LAC2001S	2	2.5000	2.515	3.031	3.125	2.938	4.625	1.625	3.000
GLAC-250-S	LAC-250-S	GLAC2501S	LAC2501S	2-1/2	3.0000	3.015	3.531	3.625	3.438	5.375	1.875	3.500
GLAC-300-S	LAC-300-S	GLAC3001S	LAC3001S	3	3.6250	3.640	4.281	4.375	4.188	5.875	1.875	4.000

EXTRA LONG SHOULDER BUSHINGS – BRONZE PLATED												
PART NUMBER Class 2*		PART NUMBER Class 1*		D1 Nom Pin Diam.	D2 Wring Fit Diameter		D3 Head OD	D4 Shoulder OD	D5 Head OD Groove	L1 Overall Length	L3 Wring Fit Length	L4 Head Length
GROUND	UNGROUND	GROUND	UNGROUND		GROUND	UNGROUND						
GXLAC-750-S	XLAC-750-S	GXLAC7501S	XLAC7501S	3/4	1.1250	1.140	1.219	1.313	1.125	3.563	0.813	2.750
GXLAC-875-S	XLAC-875-S	GXLAC8751S	XLAC8751S	7/8	1.3750	1.390	1.469	1.563	1.375	4.375	0.875	3.500
GXLAC-100-S	XLAC-100-S	GXLAC1001S	XLAC1001S	1	1.5000	1.515	1.656	1.750	1.563	4.375	0.875	3.500
GXLAC-125-S	XLAC-125-S	GXLAC1251S	XLAC1251S	1-1/4	1.7500	1.765	2.031	2.125	1.938	4.625	1.125	3.500
GXLAC-150-S	XLAC-150-S	GXLAC1501S	XLAC1501S	1-1/2	2.0000	2.015	2.281	2.375	2.188	4.875	1.375	3.500

LONG & EXTRA LONG SHOULDER BUSHINGS – SOLID STEEL											
PART NUMBER Class 2 only*		D1 Nom Pin Diam.	D2 Wring Fit Diameter		D3 Head OD	D4 Shoulder OD	D5 Head OD Groove	L1 Overall Length	L3 Wring Fit Length	L4 Head Length	
GROUND	UNGROUND		GROUND	UNGROUND							
GXLAC-750-SS	XLAC-750-SS	3/4	1.1250	1.140	1.219	1.313	1.125	3.813	0.813	3.000	
GXLAC-100-SS	XLAC-100-SS	1	1.5000	1.515	1.656	1.750	1.563	3.875	0.875	3.000	
GXLAC-125-SS	XLAC-125-SS	1-1/4	1.7500	1.765	2.031	2.125	1.938	4.125	1.125	3.000	
GXLAC-150-SS	XLAC-150-SS	1-1/2	2.0000	2.015	2.281	2.375	2.188	4.375	1.375	3.000	
GXLAC-175-SS	XLAC-175-SS	1-3/4	2.2500	2.265	2.531	2.625	2.438	4.625	1.625	3.000	
GLAC-200-SS	LAC-200-SS	2	2.5000	2.515	3.031	3.125	2.938	3.625	1.625	2.000	
GXLAC-200-SS	XLAC-200-SS	2	2.5000	2.515	3.031	3.125	2.938	4.625	1.625	3.000	
GLAC-250-SS	LAC-250-SS	2-1/2	3.0000	3.015	3.531	3.625	3.438	5.375	1.875	3.500	

## Bushings – Inch – Wring Fit Style



**BRONZE PLATED**

Grease Fittings  
 Ø3/4 - 1/4-28, 5/16 hex  
 Ø7/8 - 3" - 1/8-27 NPTF, 7/16 hex

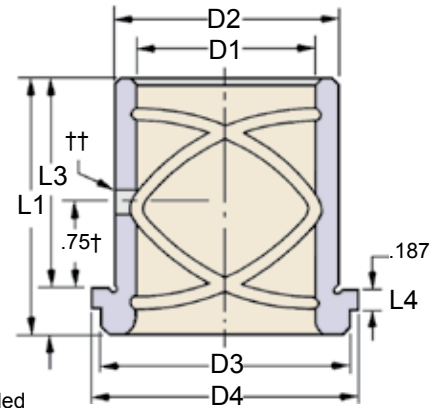

\*See page 3 for details.  
 See pages 16 & 17 for toe clamp placement instructions.

D-Clamps & Screws are included  
 with wring fit style bushings.

SHORT SHOULDER BUSHINGS – BRONZE PLATED											
PART NUMBER Class 2*		PART NUMBER Class 1*		D1 Nom Pin Diam.	D2 Wring Fit Diameter		D3 Head OD	D4 Shoulder OD	L1 Overall Length	L3 Wring Fit Length	L4 Head Length
GROUND	UNGROUND	GROUND	UNGROUND		GROUND	UNGROUND					
GSC-750-S	SC-750-S	GSC7501S	SC7501S	3/4	1.1250	1.140	1.125	1.313	1.563	1.063	0.500
GSC-750-L	SC-750-L	GSC7501L	SC7501L						2.313	1.813	
GSC-875-S	SC-875-S	GSC8751S	SC8751S	7/8	1.3750	1.390	1.375	1.563	1.563	1.063	0.500
GSC-875-L	SC-875-L	GSC8751L	SC8751L						2.313	1.813	
GSC-100-S	SC-100-S	GSC1001S	SC1001S	1	1.5000	1.515	1.563	1.750	1.875	1.375	0.500
GSC-100-L	SC-100-L	GSC1001L	SC1001L						2.875	2.375	
GSC-125-S	SC-125-S	GSC1251S	SC1251S	1-1/4	1.7500	1.765	1.938	2.125	2.375	1.875	0.500
GSC-125-L	SC-125-L	GSC1251L	SC1251L						3.375	2.875	
GSC-150-S	SC-150-S	GSC1501S	SC1501S	1-1/2	2.0000	2.015	2.188	2.375	2.375	1.875	0.500
GSC-150-L	SC-150-L	GSC1501L	SC1501L						3.375	2.875	
GSC-175-S	SC-175-S	GSC1751S	SC1751S	1-3/4	2.2500	2.265	2.438	2.625	2.875	2.375	0.500
GSC-175-L	SC-175-L	GSC1751L	SC1751L						3.875	3.375	
GSC-200-S	SC-200-S	GSC2001S	SC2001S	2	2.5000	2.515	2.750	2.938	2.875	2.375	0.500
GSC-200-L	SC-200-L	GSC2001L	SC2001L						3.875	3.375	
GSC-250-S	SC-250-S	GSC2501S	SC2501S	2-1/2	3.0000	3.015	3.188	3.375	3.000	2.625	0.375
GSC-250-M	SC-250-M	GSC2501M	SC2501M						4.000	3.625	
GSC-250-L	SC-250-L	GSC2501L	SC2501L						5.000	4.625	
GSC-300-S	SC-300-S	GSC3001S	SC3001S	3	3.5000	3.515	3.688	3.875	4.000	3.625	0.375
GSC-300-M	SC-300-M	GSC3001M	SC3001M						5.000	4.625	
GSC-300-L	SC-300-L	GSC3001L	SC3001L						6.000	5.625	

† Reference on page 9.

†† For bushing I.D.s less than 1.25, hole diameter is .188; for bushing I.D.s 1.25+, hole diameter is .344.



Lamina pins and bushings are used in die sets  
 for the metal stamping industry.



## Bushings – Inch – Wring Fit Style



**SOLID BRONZE**

Grease Fittings  
 Ø3/4 - 1/4-28, 5/16 hex  
 Ø7/8 - 3" - 1/8-27 NPTF, 7/16 hex

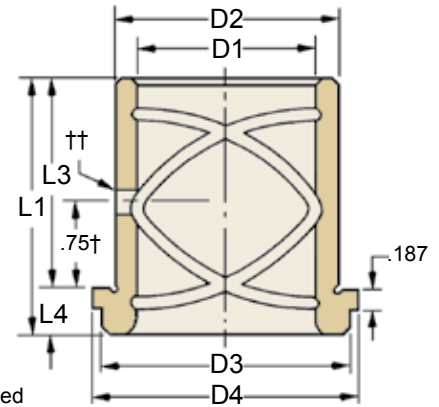

\*See page 3 for details.  
 See pages 16 & 17 for toe clamp placement instructions.

D-Clamps & Screws are included  
 with wring fit style bushings.

SHORT SHOULDER BUSHINGS –SOLID BRONZE											
PART NUMBER Class 2*		PART NUMBER Class 1*		D1 Nom Pin Diam.	D2 Wring Fit Diameter		D3 Head OD	D4 Shoul- der OD	L1 Overall Length	L3 Wring Fit Length	L4 Head Length
GROUND	UNGROUND	GROUND	UNGROUND		GROUND	UNGROUND					
GSC-750-SB	SC-750-SB	GSC7501SB	SC7501SB	3/4	1.1250	1.140	1.125	1.313	1.563	1.063	0.500
GSC-750-LB	SC-750-LB	GSC7501LB	SC7501LB						2.313	1.813	
GSC-875-SB	SC-875-SB	GSC8751SB	SC8751SB	7/8	1.3750	1.390	1.375	1.563	1.563	1.063	0.500
GSC-875-LB	SC-875-LB	GSC8751LB	SC8751LB						2.313	1.813	
GSC-100-SB	SC-100-SB	GSC1001SB	SC1001SB	1	1.5000	1.515	1.563	1.750	1.875	1.375	0.500
GSC-100-LB	SC-100-LB	GSC1001LB	SC1001LB						2.875	2.375	
GSC-125-SB	SC-125-SB	GSC1251SB	SC1251SB	1-1/4	1.7500	1.765	1.938	2.125	2.375	1.875	0.500
GSC-125-LB	SC-125-LB	GSC1251LB	SC1251LB						3.375	2.875	
GSC-150-SB	SC-150-SB	GSC1501SB	SC1501SB	1-1/2	2.0000	2.015	2.188	2.375	2.375	1.875	0.500
GSC-150-LB	SC-150-LB	GSC1501LB	SC1501LB						3.375	2.875	
GSC-175-SB	SC-175-SB	GSC1751SB	SC1751SB	1-3/4	2.2500	2.265	2.438	2.625	2.875	2.375	0.500
GSC-175-LB	SC-175-LB	GSC1751LB	SC1751LB						3.875	3.375	
GSC-200-SB	SC-200-SB	GSC2001SB	SC2001SB	2	2.5000	2.515	2.750	2.938	2.875	2.375	0.500
GSC-200-LB	SC-200-LB	GSC2001LB	SC2001LB						3.875	3.375	
GSC-250-SB	SC-250-SB	GSC2501SB	SC2501SB	2-1/2	3.0000	3.015	3.188	3.375	3.000	2.625	0.375
GSC-250-MB	SC-250-MB	GSC2501MB	SC2501MB						4.000	3.625	
GSC-250-LB	SC-250-LB	GSC2501LB	SC2501LB						5.000	4.625	
GSC-300-SB	SC-300-SB	GSC3001SB	SC3001SB	3	3.5000	3.515	3.688	3.875	4.000	3.625	0.375
GSC-300-MB	SC-300-MB	GSC3001MB	SC3001MB						5.000	4.625	
GSC-300-LB	SC-300-LB	GSC3001LB	SC3001LB						6.000	5.625	
GSC-375-B	SC-375-B	N/A	N/A	3-3/4	4.5000	4.515	4.688	4.875	7.000	6.625	0.375
GSC-450-B	SC-450-B	N/A	N/A	4-1/2	5.5000	5.515	5.688	5.875	8.000	7.625	0.375

†Bushings of 2.50" diameter and larger have 1.25" dimensions.

†† For bushing I.D.s less than 1.25, hole diameter is .188; for bushing I.D.s 1.25+, hole diameter is .344.

All Short Shoulder Bushings (**unless otherwise noted**) are to be wring fit and held in place with toe clamps and screws. This means that the bushing should be installed into the die shoe using a wringing (**circular**) motion with the heel of the hand. **Please see bore size information on page 18.**

## Bushings – Inch – Wring Fit Style



**BRONZE with SELF-LUBRICATING GRAPHITE PLUGS**

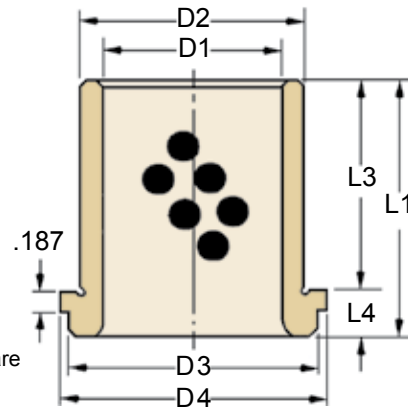

D-Clamps & Screws are included with wring fit style bushings.

\*See page 3 for details.

See pages 16 & 17 for toe clamp placement instructions.

SHORT SHOULDER BUSHINGS – SELF-LUBRICATING									
PART NUMBER		D1 Nom Pin Diam.	D2 Wring Fit Diameter		D3 Head OD	D4 Shoulder OD	L1 Overall Length	L3 Wring Fit Length	L4 Head Length
GROUND	UNGROUND		GROUND	UNGROUND					
GSCB750S	SCB750S	3/4	1.1250	1.1410	1.125	1.313	1.563	1.063	0.500
GSCB750L	SCB750L						2.313	1.813	
GSCB875S	SCB875S	7/8	1.3750	1.3910	1.375	1.563	1.563	1.063	0.500
GSCB875L	SCB875L						2.313	1.813	
GSCB100S	SCB100S	1	1.5000	1.5160	1.563	1.750	1.875	1.375	0.500
GSCB100L	SCB100L						2.875	2.375	
GSCB125S	SCB125S	1-1/4	1.7500	1.7660	1.938	2.125	2.375	1.875	0.500
GSCB125L	SCB125L						3.375	2.875	
GSCB150S	SCB150S	1-1/2	2.0000	2.0160	2.188	2.375	2.375	1.875	0.500
GSCB150L	SCB150L						3.375	2.875	
GSCB175S	SCB175S	1-3/4	2.2500	2.2660	2.438	2.625	2.875	2.375	0.500
GSCB175L	SCB175L						3.875	3.375	
GSCB200S	SCB200S	2	2.5000	2.5160	2.750	2.938	2.875	2.375	0.500
GSCB200L	SCB200L						3.875	3.375	
GSCB250S	SCB250S	2-1/2	3.0000	3.0160	3.188	3.375	3.000	2.625	0.375
GSCB250M	SCB250M						4.000	3.625	
GSCB250L	SCB250L						5.000	4.625	
GSCB300X	SCB300X	3	3.5000	3.5160	3.688	3.875	3.000	2.625	0.375
GSCB300S	SCB300S						4.000	3.625	
GSCB300M	SCB300M						5.000	4.625	
GSCB300L	SCB300L						6.000	5.625	
GSCB375S	SCB375S	3-3/4	4.5000	4.5160	4.688	4.875	7.000	6.625	0.375
GSCB450S	SCB450S	4-1/2	5.5000	5.5160	5.688	5.875	8.000	7.625	0.375

Self-lubricating bronze with graphite bushings require initial lubrication with light oil. Periodic lubrication will extend the life of self-lubricating bushings. **Do not use grease.**

## Bushings – Metric – Wring Fit Style



**BRONZE with SELF-LUBRICATING GRAPHITE PLUGS**

G720000C Clamps & Screws are included with NAAMS wring fit style bushings.

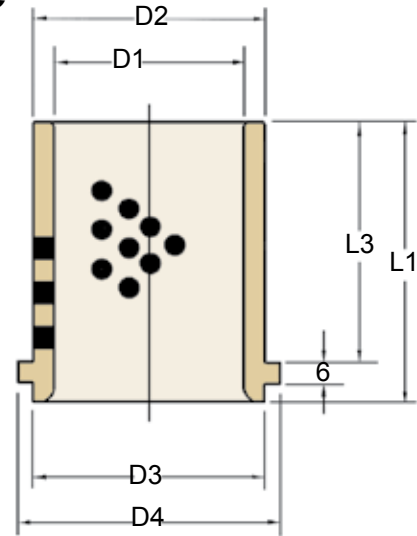

See page 17 for toe clamp placement instructions.

SHORT SHOULDER BUSHINGS – SELF-LUBRICATING – NAAMS									
PART NUMBER	D1 NOM. PIN DIAMETER	D1 TOL H6	D2 WRING FIT DIAMETER	D2 TOL G6	D3	D4	L1 OVERALL LENGTH	L3 WRING FIT LENGTH	# TOE CLAMPS & SCREWS
G612540	25	+ .013 + .000	32	- .009 - .025	32	40	40	30	3
G613250	32	+ .016 + .000	40	- .009 - .025	40	50	50	40	
G614063	40	+ .016 + .000	50	- .009 - .025	50	63	63	50	
G615071	50	+ .016 + .000	63	- .010 - .029	63	71	71	56	
G616380	63	+ .019 + .000	80	- .010 - .029	80	90	80	63	
G618010	80	+ .019 + .000	100	- .012 - .034	100	112	100	80	
G611012	100	+ .022 + .000	125	- .014 - .039	125	140	125	106	
G611114	115	+ .022 + .000	140	- .014 - .014	140	155	140	120	
G611216	125	+ .025 + .000	180	1.688 - .039	180	180	160	132	

Evenly distributed graphite covers 20-30% of the sliding surface.

Graphite is positioned to ensure overlapping in the slide direction.

See page 17 for Toe Clamp information and page 18 for bore sizes.

These short shoulder bushings are made especially for automotive stamping companies. They conform to the standards agreed to by the North American Automotive Metric Standards group.

*AUTOMOTIVE METRIC*  
**NAAMS** STANDARD

## Bushings – Metric

These pad bushings are made especially for automotive stamping companies. They conform to the standards agreed to by the North American Automotive Metric Standards group.



**BRONZE with SELF LUBRICATING GRAPHITE PLUGS**

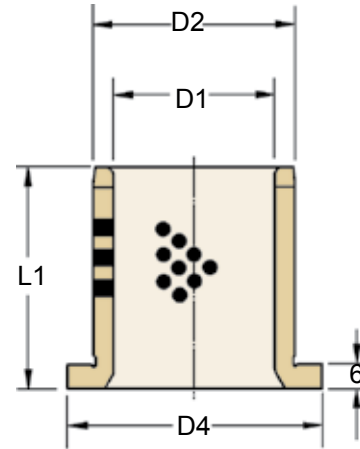

See page 17 for toe clamp installation instructions.

SELF-LUBRICATING PAD BUSHINGS – NAAMS						
PART NUMBER	D1 NOM. PIN DIAMETER	D1 TOL C9	D2 WRING FIT DIAMETER	D2 TOL G6	D4	L1 OVERALL LENGTH
<b>G712540</b>	25	+ .162 + .110	32	- .009 - .025	40	40
<b>G713250</b>	32	+ .182 + .120	40	- .009 - .025	50	50
<b>G714055</b>	40	+ .182 + .120	50	- .009 - .025	63	55
<b>G715063</b>	50	+ .192 + .130	63	- .010 - .029	71	63
<b>G716375</b>	63	+ .214 + .140	80	- .010 - .029	90	75
<b>G718090</b>	80	+ .224 + .150	100	- .012 - .034	112	90
<b>G711011</b>	100	+ .257 + .170	125	- .014 - .039	140	115
<b>G711213</b>	125	+ .300 + .200	160	- .014 - .039	180	138

**NOTE:**

Evenly distributed graphite covers 20-30% of the sliding surface.  
 Graphite is positioned to ensure overlapping in the slide direction.  
 See page 18 for bore size information.

*AUTOMOTIVE METRIC  
**NAAMS** STANDARD*

A full complement of flat products is also available from the Lamina Components line.

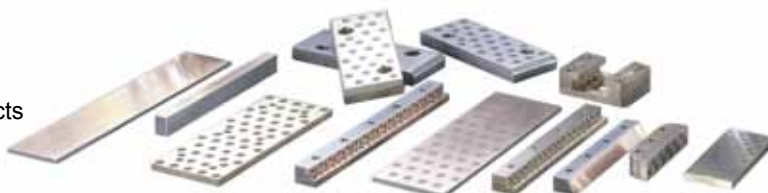

## Bushings – Metric – Wring Fit Style

Bronze plated shoulder bushings are available in metric sizes.



**BRONZE PLATED**

D-Clamps & Screws are included with wring fit style bushings.

### Grease Fittings

North America  
 Ø18 & 19mm - 1/4-28, 5/16 hex  
 Ø24-80mm - 1/8-27 NPT, 7/16 hex

Europe  
 Ø18 & 19mm - 1/4-28  
 Ø24-80mm - 1/8-27 NPT  
 (Replace "N" in Part Number with "E". E version is a straight steel flush grease fitting with screwdriver slot.)

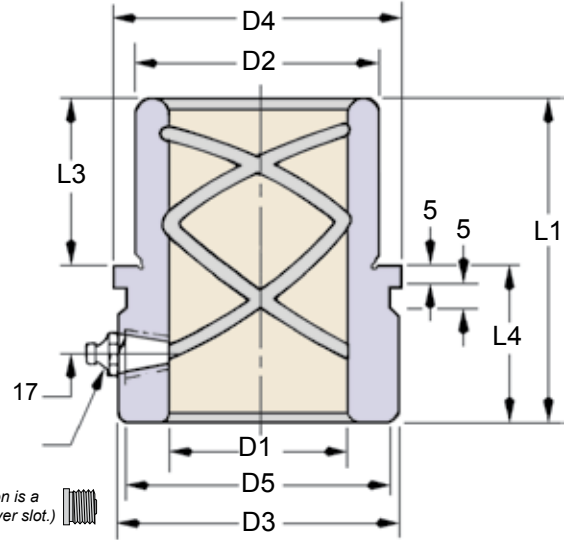

See pages 16 & 17 for toe clamp installation instructions.

STANDARD SHOULDER BUSHINGS – BRONZE PLATED – METRIC												
PART NUMBER		NOM. PIN DIA.	D1	D2 WRING FIT DIAMETER		D3 HEAD O.D.	D4 SHOULDER O.D. + 0.13 - 0.00	D5 HEAD O.D. GROOVE	L1 OVERALL LENGTH + 0.00 - 0.26	L3 WRING FIT LENGTH + 0.00 - 0.26	L4 HEAD LENGTH	# CLAMPS & SCREWS
GROUND	UNGROUND			GROUND	UNGROUND							
GAC-18SN	AC-18SN	18	18.011 18.005	28.000 27.995	28.406	31.00	34.00	29.00	50.00	18.00	32.00	2
GAC-19SN	AC-19SN	19	19.011 19.005	28.000 27.995	28.406	31.00	34.00	29.00	50.00	18.00	32.00	2
GAC-24SN	AC-24SN	24	24.011 24.005	38.000 37.992	38.406	41.00	44.00	39.00	55.00	23.00	32.00	3
GAC-25SN	AC-25SN	25	25.011 25.005	38.000 37.992	38.406	41.00	44.00	39.00	55.00	23.00	32.00	3
GAC-30SN	AC-30SN	30	30.014 30.008	45.000 44.992	45.406	50.00	53.00	48.00	60.00	26.00	34.00	3
GAC-32SN	AC-32SN	32	32.014 32.008	45.000 44.992	45.406	50.00	53.00	48.00	60.00	26.00	34.00	3
GAC-40SN	AC-40SN	40	40.014 40.008	54.000 53.992	54.406	60.00	63.00	58.00	67.00	30.00	37.00	3
GAC-42SN	AC-42SN	42	42.014 42.008	54.000 53.992	54.406	60.00	63.00	58.00	67.00	30.00	37.00	3
GAC-50SN	AC-50SN	50	50.014 50.008	65.000 64.992	65.406	76.00	79.00	74.00	75.00	35.00	40.00	4
GAC-52SN	AC-52SN	52	52.014 52.008	65.000 64.992	65.406	76.00	79.00	74.00	75.00	35.00	40.00	4
GAC-63SN	AC-63SN	63	63.016 63.010	81.000 80.990	81.406	89.00	92.00	87.00	88.00	46.00	42.00	4
GAC-80SN	AC-80SN	80	80.016 80.010	100.000 99.990	100.406	108.00	111.00	106.00	98.00	46.00	52.00	4

\*Unground wring fit tolerance is +0.000 -0.013.

All Standard Shoulder Bushings (**unless otherwise noted**) are to be wring fit and held in place with toe clamps and screws. This means that the bushing should be installed into the die shoe using a wringing (**circular**) motion with the heel of the hand. **Please see clamping information on pages 16 & 17 and bore size information on page 18.**

## Bushings – Metric – Wring Fit Style



D-Clamps & Screws are included with wring fit style bushings.

### Grease Fittings

North America  
 Ø18 & 19mm - 1/4-28, 5/16 hex  
 Ø24-80mm - 1/8-27 NPT, 7/16 hex

Europe  
 Ø18 & 19mm - 1/4-28  
 Ø24-80mm - 1/8-27 NPT  
 (Replace "N" in Part Number with "E". E version is a straight steel flush grease fitting with screwdriver slot.)

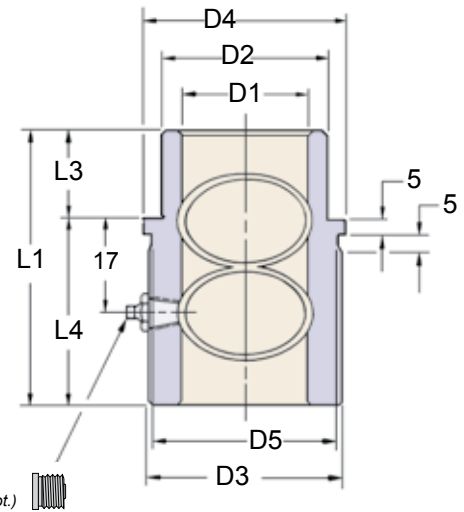

See pages 16 & 17 for toe clamp placement instructions.

LONG & EXTRA LONG SHOULDER BUSHINGS – BRONZE PLATED – METRIC												
PART NUMBER		NOM. PIN DIA.	D1	D2 WRING FIT O.D.		D3 HEAD O.D.	D4 SHOULDER O.D. +0.13 / -0.00	D5 HEAD O.D. GROOVE	L1 OVERALL LENGTH +0.00 / -0.26	L3 WRING FIT LENGTH +0.00 / -0.26	L4 HEAD LENGTH	# CLAMPS & SCREWS
GROUND	UNGROUND			GROUND	UNGROUND							
GLAM-18FN	LAM-18FN	18	18.011	28.000	28.406	31.00	34.00	29.00	69.00	26.00	43.00	2
GLAC-18SN	LAC-18SN		18.005	27.995								
GLAM-19FN	LAM-19FN	19	19.011	28.000	28.406	31.00	34.00	29.00	69.00	26.00	43.00	2
GLAC-19SN	LAC-19SN		19.005	27.995								
GLAM-24FN	LAM-24FN	24	24.011	38.000	38.406	41.00	44.00	39.00	80.00	32.00	48.00	3
GLAC-24SN	LAC-24SN		24.005	37.992								
GLAM-25FN	LAM-25FN	25	25.011	38.000	38.406	41.00	44.00	39.00	80.00	32.00	48.00	3
GLAC-25SN	LAC-25SN		25.005	37.992								
GLAM-30FN	LAM-30FN	30	30.014	45.000	45.406	50.00	53.00	48.00	89.00	36.00	53.00	3
GLAC-30SN	LAC-30SN		30.008	44.992								
GLAM-32FN	LAM-32FN	32	32.014	45.000	45.406	50.00	53.00	48.00	89.00	36.00	53.00	3
GLAC-32SN	LAC-32SN		32.008	44.992								
GLAM-40FN	LAM-40FN	40	40.014	54.000	54.406	60.00	63.00	58.00	99.00	46.00	53.00	3
GLAC-40SN	LAC-40SN		40.008	53.992								
GLAM-42FN	LAM-42FN	42	42.014	54.000	54.406	60.00	63.00	58.00	99.00	46.00	53.00	3
GLAC-42SN	LAC-42SN		42.008	53.992								
GLAM-50FN	LAM-50FN	50	50.014	65.000	65.406	76.00	79.00	74.00	109.00	56.00	53.00	4
GLAC-50SN	LAC-50SN		50.008	64.992								
GLAM-52FN	LAM-52FN	52	52.014	65.000	65.406	76.00	79.00	74.00	109.00	56.00	53.00	4
GLAC-52SN	LAC-52SN		52.008	64.992								
GLAM-63FN	LAM-63FN	63	63.016	81.000	81.406	89.00	92.00	87.00	129.00	66.00	63.00	4
GLAC-63SN	LAC-63SN		63.010	80.990								
GLAM-80FN	LAM-80FN	80	80.016	100.000	100.406	108.00	111.00	106.00	149.00	76.00	73.00	4
GLAC-80SN	LAC-80SN		80.010	99.990								

\*Unground wring fit tolerance is +0.000 –0.013.

All Standard Shoulder Bushings (**unless otherwise noted**) are to be wring fit and held in place with toe clamps and screws. This means that the bushing should be installed into the die shoe using a wringing (**circular**) motion with the heel of the hand. **Please see clamping information on pages 16 & 17 and bore size information on page 18.**

# Bushings – Metric – Wring Fit Style



D-Clamps & Screws are included with wring fit style bushings.

**Grease Fittings**  
 North America  
 Ø18 & 19mm - 1/4-28, 5/16 hex  
 Ø24-80mm - 1/8-27 NPT, 7/16 hex

Europe  
 Ø18 & 19mm - 1/4-28  
 Ø24-80mm - 1/8-27 NPT  
 (Replace "N" in Part Number with "E". E version is a straight steel flush grease fitting with screwdriver slot.)

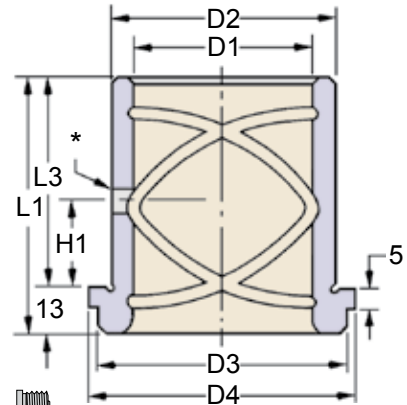

\*Ø4.76 for bushings with nom. I.D.s between 18 & 32mm.  
 \*Ø8.73 for bushings with nom. I.D.s between 40 & 80mm.

See pages 16 & 17 for toe clamp placement instructions.

SHORT SHOULDER BUSHINGS – BRONZE PLATED – METRIC											
PART NUMBER		NOM. PIN DIA.	D1	D2 WRING FIT DIAMETER		D3 HEAD O.D.	D4 SHOULDER O.D. +0.13 / -0.00	L1 OVERALL LENGTH +0.00 / -0.26	L3 WRING FIT LENGTH +0.00 / -0.26	H1 LUBE HOLE CENTER	# CLAMPS & SCREWS
GROUND	UNGROUND			GROUND	UNGROUND						
GSC-18SN	SC-18SN	18	18.011	28.000	28.406	29.00	34.00	31.00	18.00	8.00	2
GSCL-18FN	SCL-18FN		18.005	27.995							
GSC-19SN	SC-19SN	19	19.011	28.000	28.406	29.00	34.00	31.00	18.00	8.00	2
GSCL-19FN	SCL-19FN		19.005	27.995							
GSC-24SN	SC-24SN	24	24.011	38.000	38.406	39.00	44.00	36.00	23.00	12.00	3
GSCL-24FN	SCL-24FN		24.005	37.992							
GSC-25SN	SC-25SN	25	25.011	38.000	38.406	39.00	44.00	36.00	23.00	12.00	3
GSCL-25FN	SCL-25FN		25.005	37.992							
GSC-30SN	SC-30SN	30	30.014	45.000	45.406	48.00	53.00	43.00	30.00	15.00	3
GSCL-30FN	SCL-30FN		30.008	44.992							
GSC-32SN	SC-32SN	32	32.014	45.000	45.406	48.00	53.00	43.00	30.00	15.00	3
GSCL-32FN	SCL-32FN		32.008	44.992							
GSC-40SN	SC-40SN	40	40.014	54.000	54.406	58.00	63.00	49.00	36.00	19.00	3
GSCL-40FN	SCL-40FN		40.008	53.992							
GSC-42SN	SC-42SN	42	42.014	54.000	54.406	58.00	63.00	49.00	36.00	19.00	3
GSCL-42FN	SCL-42FN		42.008	53.992							
GSC-50SN	SC-50SN	50	50.014	65.000	65.406	74.00	79.00	59.00	46.00	19.00	4
GSCL-50FN	SCL-50FN		50.008	64.992							
GSC-52SN	SC-52SN	52	52.014	65.000	65.406	74.00	79.00	59.00	46.00	19.00	4
GSCL-52FN	SCL-52FN		52.008	64.992							
GSC-63SN	SC-63SN	63	63.016	81.000	81.406	87.00	92.00	74.00	61.00	19.00	4
GSCL-63FN	SCL-63FN		63.010	80.990							
GSC-80SN	SC-80SN	80	80.016	100.000	100.406	106.00	111.00	89.00	76.00	19.00	4
			80.010	99.990							

\*Unground wring fit tolerance is +0.000 –0.013.

All Standard Shoulder Bushings (**unless otherwise noted**) are to be wring fit and held in place with toe clamps and screws. This means that the bushing should be installed into the die shoe using a wringing (**circular**) motion with the heel of the hand. **Please see clamping information on pages 16 & 17 and bore size information on page 18.**

## Toe Clamp Information for Inch & Metric Plain Bearing Die Bushings

CLAMP & SCREW PLACEMENT											
INCH								METRIC			
Bushing I.D.	# Provided	Bolt Circle Diameter						Bushing I.D. AC, LAM, LAC, SC	# Provided	Bolt Circle Diameter	
		D-Clamps			X-40 Clamps					D-Clamps	X-40 Clamps
		AC, LAC, XLAC	SC	LMB	AC, LAC, XLAC	SC	LMB				
0.625	2	N/A	N/A	1.531	N/A	N/A	1.644	18	2	45	47.18
0.750	2	1.719	1.719	1.719	1.831	1.831	1.891	19	2	45	47.18
0.875	2	1.969	1.969	N/A	2.081	2.081	N/A	24	3	55	57.18
1.000	3	2.156	2.156	2.156	2.269	2.269	2.269	25	3	55	57.18
1.250	3	2.531	2.531	2.531	2.644	2.644	2.644	30	3	64	66.18
1.500	3	2.781	2.781	2.781	2.894	2.894	2.894	32	3	64	66.18
1.750	3	3.031	3.031	3.031	3.144	3.144	3.144	40	3	74	76.18
2.000	4	3.531	3.344	3.344	3.644	3.456	3.456	42	3	74	76.18
2.500	4	4.031	3.781	4.031	4.174	3.894	4.174	50	4	90	92.18
3.000	6	4.781	4.281	4.531	4.944	4.424	4.694	52	4	90	92.18
3.750	6	5.281	5.281	5.281	5.281	5.424	5.444	63	4	103	105.94
4.500	6	6.281	6.281	6.281	6.281	6.444	6.444	80	4	122	125.45

### Toe Clamp Dimensions

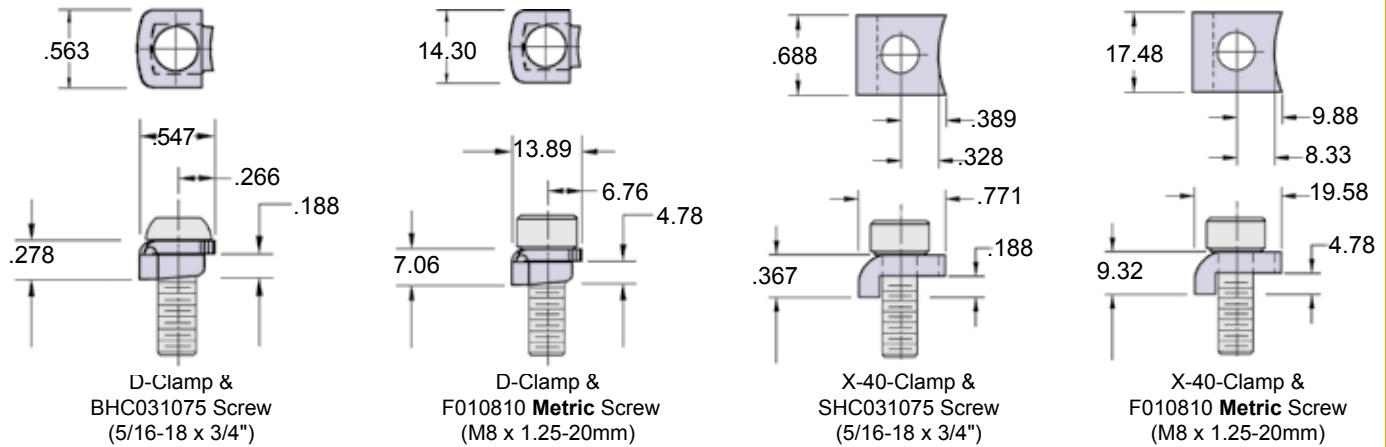

### REPLACEMENT KITS – CLAMPS & SCREWS

D-CLAMPS							
INCH				METRIC			
PART NUMBER	Nom. Pin Diameter	# Clamps & Screws per Kit	# Kits Needed	PART NUMBER	Nom. Pin Diameter	# Clamps & Screws per Kit	# Kits Needed
CSK100002	5/8 – 7/8	2	1	CSK100052	18 – 19	2	1
CSK100003	1 – 1-3/4	3	1	CSK100053	24 – 42	3	1
CSK100002	2 – 2-1/2	2	2	CSK100052	50 – 80	2	2
CSK100003	3 – 4-1/2	3	2				

X-40 CLAMPS							
INCH				METRIC			
PART NUMBER	Nom. Pin Diameter	# Clamps & Screws per Kit	# Kits Needed	PART NUMBER	Nom. Pin Diameter	# Clamps & Screws per Kit	# Kits Needed
CSK200002	5/8 – 7/8	2	1	CSK20052	18 – 19	2	1
CSK200003	1 – 1-3/4	3	1	CSK20053	24 – 42	3	1
CSK200002	2 – 2-1/2	2	2	CSK20052	50 – 80	2	2
CSK200003	3 – 4-1/2	3	2				

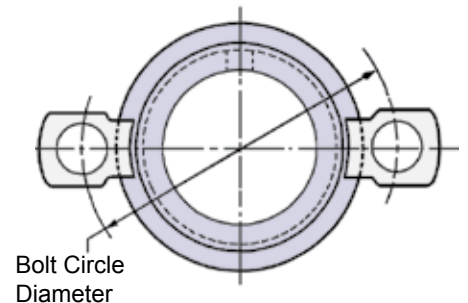

Drawing above can refer to either D-Clamps or X-40-Clamps



# Toe Clamp Information for Inch & Metric Demountable Components

BALL-BEARING DEMOUNTABLE COMPONENT CLAMP ARRANGEMENTS			
NOM. PIN DIA.	STANDARD LEFT - RIGHT FEED	FRONT to BACK FEED (Center Post Die Sets)	ROUND DIES
1, 1 1/4, & 1 1/2			
1 3/4, 2, 2 1/2, & 3			
1 3/4, 2, 2 1/2, & 3			
1 3/4, 2, 2 1/2, & 3			

BOLT CIRCLE DIAMETERS	
<b>DEMOUNTABLE BALL BEARING BUSHINGS</b>	
Nominal Bushing Diameter	Bolt Circle Diameter
1	2.438
1-1/4	2.813
1-1/2	3.125
1-3/4	3.438
2	4.000
2-1/2	4.500
3	5.000
<b>DEMOUNTABLE BALL BEARING &amp; PLAIN BEARING PINS</b>	
Nominal Pin Diameter	Bolt Circle Diameter
1	1.750
1-1/4	2.000
1-1/2	2.250
1-3/4	2.625
2	2.875
2-1/2	3.375
3	3.875
<b>KEYLESS DEMOUNTABLE BALL BEARING BUSHINGS</b>	
Nominal Bushing Diameter	Bolt Circle Diameter
1	2.625
1-1/4	2.875
1-1/2	3.375
1-3/4	3.625
2	4.125
2-1/2	4.625
3	5.250
<b>KEYLESS DEMOUNTABLE BALL BEARING PINS</b>	
Nominal Pin Diameter	Bolt Circle Diameter
1	1.625
1-1/4	1.969
1-1/2	2.250
1-3/4	2.594
2	2.884
2-1/2	3.344
3	3.844

## BUSHING CLAMPING PROCEDURES

*AUTOMOTIVE METRIC*

*NAAMS STANDARD*

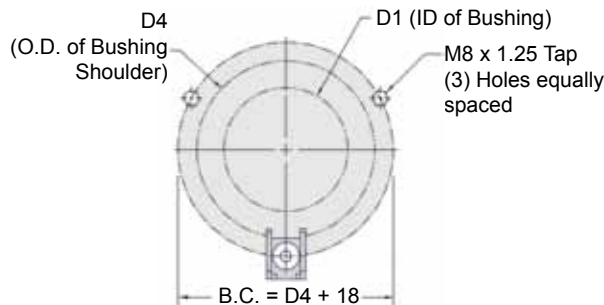
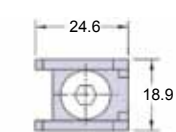

Clamp Part No: G720000C  
M8 x 1.25 x 20 Long

D1	D4	B.C. (D4 + 18)
25	40	58
32	50	68
40	63	81
50	71	89
63	90	108
80	112	130
100	140	158
115	155	173
125	180	198

### NOTES & SPECIFICATIONS:

Bushings will be supplied with (3) toe clamps and (3) screws - M8. Screws must engage 16mm minimum deep into die shoe.

**RECOMMENDED BORE SIZES FOR PLAIN BEARING PINS & BUSHINGS**

Nominal Pin Diameter	Standard Inch GAC, GLAC, GXLAC & GSC Style Bushings	Standard Metric GAC, GLAC, GLAM & GSC Style Bushings	Short Shoulder & Pad Bushings NAAMS	Bushing Liner for Removable Pin	Straight Guide Pins Inch TN & ATN	Straight Guide Pins Metric TN	Straight Guide Pins Inch TPC	Straight Guide Pins Metric NAAMS	Guide Pins with Shoulders Metric NAAMS	D'mountable Inch Guide Pins	Standard Metric Guide Pins					
	WRING FIT	WRING FIT	WRING FIT	PRESS FIT	PRESS FIT	PRESS FIT	PRESS FIT	PRESS FIT	TAP FIT	TAP FIT	TAP FIT					
3/4 in	<u>1.1255</u> 1.1250	N/A	N/A	N/A	<u>0.7485</u> 0.7480	N/A	<u>0.7505</u> 0.7500	N/A	N/A	N/A	N/A					
7/8 in	<u>1.3755</u> 1.3750			N/A	N/A		<u>0.8755</u> 0.8750			N/A						
1 in	<u>1.5005</u> 1.5000			<u>1.4988</u> 1.4983	<u>0.9985</u> 0.9980		<u>1.0005</u> 1.0000			<u>1.0005</u> 1.0000						
1-1/4 in	<u>1.7505</u> 1.7500			<u>1.7488</u> 1.7483	<u>1.2480</u> 1.2475		<u>1.2505</u> 1.2500			<u>1.2505</u> 1.2500						
1-1/2 in	<u>2.0005</u> 2.0000			<u>1.9983</u> 1.9978	<u>1.4980</u> 1.4975		<u>1.5005</u> 1.5000			<u>1.5005</u> 1.5000						
1-3/4 in	<u>2.2505</u> 2.2500			<u>2.2483</u> 2.2478	<u>1.7480</u> 1.7475		<u>1.7505</u> 1.7500			<u>1.7505</u> 1.7500						
2 in	<u>2.5005</u> 2.5000			<u>2.4983</u> 2.4978	<u>1.9975</u> 1.9970		<u>2.0000</u> 1.9995			<u>2.0000</u> 1.9995						
2-1/2 in	<u>3.0005</u> 3.0000			<u>2.9983</u> 2.9978	<u>2.4975</u> 2.4970		<u>2.5000</u> 2.4995			<u>2.5000</u> 2.4995						
3 in GSC ONLY	<u>3.5005</u> 3.5000			N/A	N/A		N/A			N/A						
3 in	<u>3.6255</u> 3.6250			<u>3.4983</u> 3.4978	<u>2.9975</u> 2.9970		<u>3.0000</u> 2.9995			<u>3.0000</u> 2.9995						
3-3/4 in	<u>4.5005</u> 4.5000			N/A	N/A		<u>3.7500</u> 3.7495			<u>3.7500</u> 3.7495						
4-1/2 in	<u>5.5005</u> 5.5000			N/A	N/A		<u>4.5000</u> 4.4995			<u>4.5000</u> 4.4995						
18mm	N/A			<u>28.013</u> 28.000	N/A		N/A			N/A		N/A	N/A	N/A	N/A	N/A
19mm				<u>28.013</u> 28.000	N/A							<u>18.980</u> 18.959	N/A	<u>18.980</u> 18.959		
24mm				<u>38.016</u> 38.000	N/A							N/A	N/A	N/A		
25mm				<u>38.016</u> 38.000	N/A							<u>24.980</u> 24.959	N/A	<u>24.980</u> 24.959		
30mm		<u>45.016</u> 45.000	N/A	N/A	N/A	N/A										
32mm		<u>45.016</u> 45.000	<u>40.025</u> 40.000	<u>31.975</u> 31.950	<u>32.025</u> 32.000	<u>32.060</u> 32.050										
40mm		<u>54.019</u> 54.000	<u>50.025</u> 50.000	N/A	<u>40.025</u> 40.000	<u>40.060</u> 40.050										
42mm		<u>54.019</u> 54.000	N/A	N/A	N/A	N/A										
50mm		<u>65.019</u> 65.000	<u>63.030</u> 63.000	N/A	<u>50.025</u> 50.000	<u>50.060</u> 50.050										
52mm		<u>65.019</u> 65.000	N/A	N/A	N/A	N/A										
63mm		<u>81.022</u> 81.000	<u>80.030</u> 80.000	N/A	<u>63.030</u> 63.000	<u>63.070</u> 63.060										
80mm		<u>100.022</u> 100.000	<u>100.035</u> 100.000	N/A	<u>80.030</u> 80.000	<u>80.072</u> 80.062										
100mm		N/A	<u>125.040</u> 125.000	N/A	<u>100.035</u> 100.000	<u>100.083</u> 100.073										
115mm		N/A	<u>140.040</u> 140.000	N/A	<u>115.035</u> 115.000	<u>115.035</u> 115.000										
125mm		N/A	<u>160.040</u> 160.000	N/A	<u>125.040</u> 125.000	<u>125.040</u> 125.000										

**DEFINITIONS OF MOUNTING PROCEDURES**  
**Pins and bushings require specific mounting procedures. By following these procedures the components should give maximum life and reduce downtime due to improper alignment, breakage and uneven wear.**

**Press Fit** – The component is installed in an interference condition: the bore size is smaller than the press fit portion of the component.

**Bushings** that require a press fit should never be frozen or hammered. They should be forced into place using a hydraulic press or other proper tooling. Improper methods can permanently change the tolerance of the component.

**Pins** can be forced into place using a hydraulic press; or the pins can be frozen and pressed into place. **Lamina does not recommend hammering pins into place. Hammering can cause the pins to 'mushroom' or expand on the pin**

**end resulting in permanent distortion of the component.**

**Tap Fit** – The component should be tapped using a soft hammer into the bored hole and secured with toe clamps.

**Wring Fit** – The component should be installed using a wringing (circular) motion with the heel of the hand. Wring fit components are to be held in place with toe clamps, retaining rings or plates.

## Bearings – Press Fit



HEAT TREATED

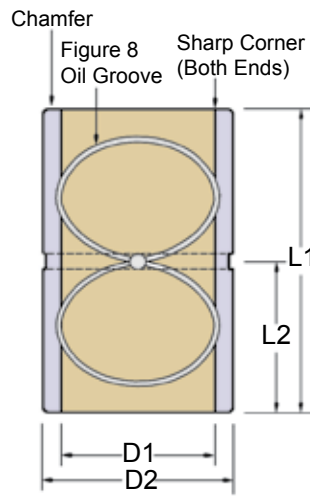

- For Machine Tools, Fixtures, etc.
- Straight Design, Wiper type
- Lamina-Bronze on steel provides longer wearing running fits
- No reaming or honing after press fitting bearing

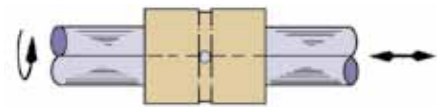

Bearings for Radial or Linear Applications

BEARINGS – RUNNING FIT – HARDENED									
PART NUMBER	D1 I.D. + .0005 - .0000	D2 O.D. + .0004 - .0000	RECOM- MENDED BORE SIZE + .0005 - .0000	L LENGTH	PART NUMBER	D1 I.D. + .0005 - .0000	D2 O.D. + .0004 - .0000	RECOM- MENDED BORE SIZE + .0005 - .0000	L LENGTH
625-x-75-RFB	0.6270	1.0014	0.9995	0.75	175-x-175-RFB	1.7530	2.2518	2.2495	1.75
625-x-100-RFB				1.00	175-x-200-RFB				2.00
625-x-125-RFB				1.25	175-x-250-RFB				2.50
750-x-75-RFB	0.7525	1.1264	1.1245	0.75	175-x-300-RFB	2.0035	2.5018	2.4995	3.00
750-x-100-RFB				1.00	175-x-350-RFB				3.50
750-x-125-RFB				1.25	200-x-200-RFB				2.00
750-x-150-RFB	1.0025	1.3764	1.3745	1.50	200-x-250-RFB	2.5035	3.2518	3.2490	2.50
100-x-100-RFB				1.00	200-x-300-RFB				3.00
100-x-125-RFB				1.25	200-x-350-RFB				3.50
100-x-150-RFB	1.0025	1.3764	1.3745	1.50	200-x-400-RFB	3.0040	3.752 + .0005* - .0000	3.7490	4.00
100-x-175-RFB				1.75	250-x-250-RFB				2.50
100-x-200-RFB				2.00	250-x-300-RFB				3.00
125-x-125-RFB	1.2530	1.7516	1.7495	1.25	250-x-350-RFB	3.0040	3.752 + .0005* - .0000	3.7490	3.50
125-x-150-RFB				1.50	250-x-400-RFB				4.00
125-x-175-RFB				1.75	250-x-450-RFB				4.50
125-x-200-RFB	1.2530	1.7516	1.7495	2.00	250-x-500-RFB	3.0040	3.752 + .0005* - .0000	3.7490	5.00
125-x-250-RFB				2.50	300-x-300-RFB				3.00
150-x-150-RFB				1.50	300-x-350-RFB				3.50
150-x-175-RFB	1.5030	2.0016	1.9995	1.75	300-x-400-RFB	3.0040	3.752 + .0005* - .0000	3.7490	4.00
150-x-200-RFB				2.00	300-x-450-RFB				4.50
150-x-250-RFB				2.50	300-x-500-RFB				5.00
150-x-300-RFB	1.5030	2.0016	1.9995	3.00	300-x-600-RFB	3.0040	3.752 + .0005* - .0000	3.7490	6.00

\*This diameter only.

## Bearings – Press Fit



NON-HEAT TREATED

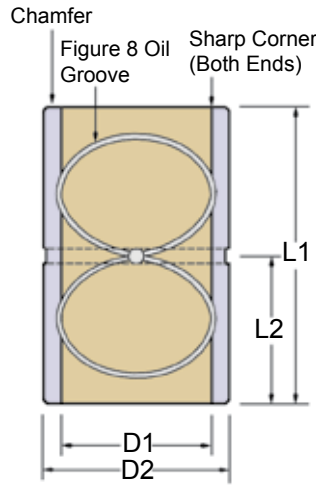

- For Machine Tools, Fixtures, etc.
- Straight Design, Wiper type
- Lamina-Bronze on steel provides longer wearing running fits
- Flash-plated O.D. prevents scoring when pressing bearing in and out

BEARINGS – RUNNING FIT –NON-HEAT-TREATED									
PART NUMBER	D1 I.D. + 0005 - .0000	D2 O.D. + 0004 - .0000	RECOM- MENDED BORE SIZE + 0005 - .0000	L LENGTH	PART NUMBER	D1 I.D. + 0005 - .0000	D2 O.D. + 0004 - .0000	RECOM- MENDED BORE SIZE + 0005 - .0000	L LENGTH
SRFB-75-x-75	0.7525	1.1265	1.1245	0.75	SRFB-175-x-200	1.7530	2.1265	2.1245	2.00
SRFB-75-x-100				1.00	SRFB-175-x-225				2.25
SRFB-75-x-125				1.25	SRFB-175-x-250				2.50
SRFB-75-x-150				1.50	SRFB-175-x-300				3.00
SRFB-100-x-75	1.0025	1.3765	1.3745	0.75	SRFB-200-x-100	2.0035	2.3765	2.3745	1.00
SRFB-100-x-100				1.00	SRFB-200-x-125				1.25
SRFB-100-x-125				1.25	SRFB-200-x-150				1.50
SRFB-100-x-150				1.50	SRFB-200-x-200				2.00
SRFB-100-x-175				1.75	SRFB-200-x-250				2.50
SRFB-100-x-200				2.00	SRFB-200-x-300				3.00
SRFB-125-x-75	1.2530	1.6265	1.6245	0.75	SRFB-200-x-350	2.5035	2.8765	2.8745	3.50
SRFB-125-x-100				1.00	SRFB-200-x-400				4.00
SRFB-125-x-125				1.25	SRFB-250-x-125				1.25
SRFB-125-x-150				1.50	SRFB-250-x-150				1.50
SRFB-125-x-175				1.75	SRFB-250-x-200				2.00
SRFB-125-x-200				2.00	SRFB-250-x-250				2.50
SRFB-125-x-250	2.50	SRFB-250-x-300	3.00						
SRFB-150-x-75	1.5030	1.8765	1.8745	0.75	SRFB-250-x-350	3.0040	+ .0005* - .0000	3.4995	3.50
SRFB-150-x-100				1.00	SRFB-250-x-400				4.00
SRFB-150-x-125				1.25	SRFB-250-x-500				5.00
SRFB-150-x-150				1.50	SRFB-300-x-150				1.50
SRFB-150-x-175				1.75	SRFB-300-x-200				2.00
SRFB-150-x-200				2.00	SRFB-300-x-250				2.50
SRFB-150-x-250	2.50	SRFB-300-x-300	3.00						
SRFB-175-x-100	1.7530	2.1265	2.1245	1.00	SRFB-300-x-350	3.0040	3.5020	3.4995	3.50
SRFB-175-x-125				1.25	SRFB-300-x-400				4.00
SRFB-175-x-150				1.50	SRFB-300-x-500				5.00
SRFB-175-x-175				1.75	SRFB-300-x-600				6.00

\*This diameter only.

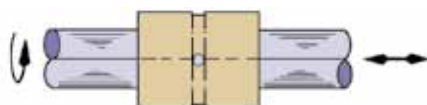

Bearings for Radial or Linear Applications

# Guide Bar Bushings – Wring Fit Style

- Used in Transfer Machinery
- Bronze Plated Steel for strength and lubricity

Guide Bar Bushings are to be wring fit and held in place with toe clamps & screws. Please see clamping information on pages 16 & 17 and bore size information on page 18.



Wiper Head

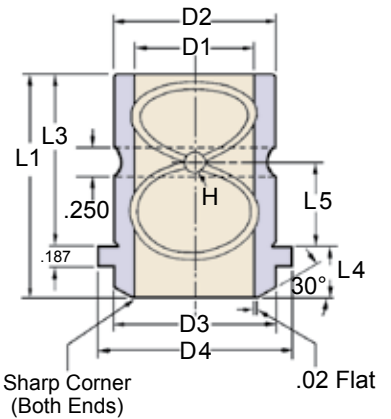

GUIDE BAR BUSHINGS													
PART NUMBER		D1	D2		D3	D4	L1	L3	L4	L5	H	# CLAMPS & SCREWS	Recommended Bore Size
GROUND	UNGROUND		GROUND	UNGROUND									
GLMB-062	LMB-062	0.6254 0.6252	1.0000	1.0160	0.930	1.125	1.210	0.750	0.460	0.370	0.188	2	1.0005
GLMB-075	LMB-075	0.7504 0.7502	1.1250	1.1410	1.120	1.313	1.230	0.750	0.480	0.370			1.0000
GLMB-100	LMB-100	1.0004 1.0002	1.3750	1.3910	1.560	1.750	1.550	1.000	0.550	0.490			1.1255
GLMB-125	LMB-125	1.2504 1.2502	1.7500	1.7660	1.930	2.125	1.940	1.375	0.565	0.690	0.188	3	1.1250
GLMB-150	LMB-150	1.5004 1.5002	2.0000	2.0160	2.180	2.375	2.060	1.500	0.560	0.750			1.3755
GLMB-175	LMB-175	1.7504 1.7502	2.2500	2.2660	2.430	2.625	2.310	1.750	0.560	0.880			1.3750
GLMB-200	LMB-200	2.0004 2.0002	2.5000	2.5160	2.750	2.938	2.570	2.000	0.570	1.000	0.250	4	1.7505
GLMB-250	LMB-250	2.5006 2.5004	3.2500	3.2660	3.430	3.625	3.120	2.500	0.620	1.250			2.0005
GLMB-300	LMB-300	3.0008 3.0006	3.7500	3.7660	3.930	4.125	3.620	3.000	0.620	1.500			2.0000
GLMB-375	LMB-375	3.7508 3.7506	4.5000	4.5160	4.680	4.875	4.370	3.750	0.620	1.870	0.250	6	2.2505
GLMB-450	LMB-450	4.5008 4.5006	5.5000	5.5160	5.680	5.875	5.200	4.500	0.700	2.250			2.2500
													2.5000
													3.2505
													3.2500
													3.7505
													3.7500
													4.5005
													4.5000
													5.5005
													5.5000

D-Clamps & Screws are included with wring fit style bushings.

# Bearings – Press Fit

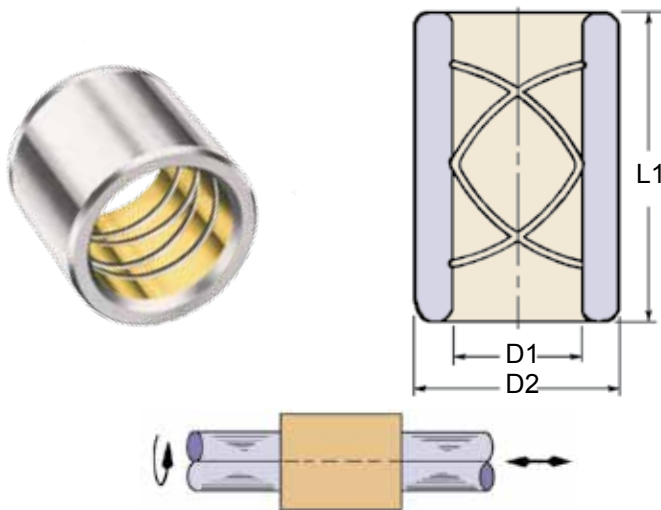

Bearings for Radial or Linear Applications

PRECISION BEARINGS					
	PART NUMBER	D1 Nom. Pin Diameter	D1	D2	L
STANDARD	B-6-175	3/4	0.7502 0.7500	1.1272 1.1268	1-3/4
	B-7-175	7/8	0.8752 0.8750	1.3772 1.3768	
	B-8-175	1	1.0002 1.0000	1.5022 1.5018	
	B-10-200	1-1/4	1.2502 1.2500	1.7522 1.7518	2
	B-12-200	1-1/2	1.5002 1.5000	2.0022 2.0018	
EXTRA-LONG	B-7-300	7/8	0.8752 0.8750	1.3772 1.3768	3
	B-8-300	1	1.0002 1.0000	1.5022 1.5018	
	B-10-300	1-1/4	1.2512 1.2500	1.7522 1.7518	
	B-12-300	1-1/2	1.5002 1.5000	2.0022 2.0018	
	B-14-300	1-3/4	1.7502 1.7500	2.2522 2.2518	
	B-16-300	2	2.0002 2.0000	2.5022 2.5018	
	B-20-300	2-1/2	2.5002 2.5000	3.0022 3.0018	

## General Information – Guide Pins

Below are listed standard diameters and minimum/maximum lengths that we are able to machine to your specifications. We can also manufacture in-between diameters.

We are able to make specials to meet your exact specifications. Please call, fax or e-mail for a quotation form. **Every quote will be answered!**

MINIMUM & MAXIMUM PIN LENGTHS					
INCH			METRIC		
Outside Diameter (in)	Minimum Length (in)	Maximum Length (in)	Outside Diameter (mm)	Minimum Length (mm)	Maximum Length (mm)
0.625	1.0	12	—	25	305
0.750			18 & 19		
0.875			—		
1.000		20	24 & 25		510
1.125			—		
1.250			30 & 32		
1.375		30	—		775
1.500			—		
1.625			—		
1.750			40 & 42		
1.875			—		
2.000			50 & 52		
2.125			—		
2.250			63		
2.375			—		
2.500			—		
2.625		39	—		1000
2.750			—		
2.875			—		
3.000			—		
3.125			—		
3.250			80		
3.375			—		
3.500			—		
3.625			—		
3.750			—		
3.875			—		
4.000			100		
4.125			—		
4.250		—			
4.375	—				
4.500	115				
4.625	—				
4.750	—				
4.875	—				
5.000	125				

### TN, ATN, TPB & TPC STRAIGHT PINS

Lamina TPB & TPC Pins dimensions shown opposite for use in precision die sets.

(Pins Available in Class 2)

### SHOULDER PINS

For use with automotive, hardware, forming, or draw dies where stamping stock is thicker than 1/16", and clearances between punch and die sections will be more than .003" per side.

(Pins available in Class 2)

### REMOVABLE PINS

Designed specifically for all dies where it is desirable to remove pins for ease and simplicity of sharpening die.

Lamina removable pins are generally used in carbide dies, progressive dies, lamination dies, and dies for very thin materials where clearances between punch and die sections will be no more than .0007" per side.

DIE PIN TOLERANCES						
Diameter	D1 Dimension				D2 Dimension	
	TN Tolerance	ATN Tolerance	HP Tolerance	TPB & TPC Tolerance	TPC Press Diameter	Press Diameter
0.7500	+ .0000 - .0002	N/A	N/A	+ .0000 - .0003	+ .0000 - .0006	0.7520
0.8750	N/A	N/A	N/A	+ .0000 - .0003	+ .0000 - .0006	0.8770
1.0000	+ .0000 - .0002	N/A	- .0003 - .0006	+ .0000 - .0003	+ .0000 - .0006	1.0020
1.2500	+ .0000 - .0004	N/A	- .0003 - .0007	+ .0000 - .0004	+ .0000 - .0008	1.2525
1.5000	+ .0000 - .0004	N/A	- .0003 - .0007	+ .0000 - .0004	+ .0000 - .0008	1.5025
1.7500	N/A	+ .0000 - .0003	- .0004 - .0009	+ .0000 - .0005	+ .0000 - .0008	1.7525
2.0000	N/A	+ .0000 - .0003	- .0004 - .0009	+ .0000 - .0005	+ .0000 - .0008	2.0025
2.5000	N/A	+ .0000 - .0003	- .0006 - .0011	+ .0000 - .0005	+ .0000 - .0008	2.5025
3.0000	N/A	+ .0000 - .0003	- .0006 - .0012	+ .0000 - .0006	+ .0000 - .0008	3.0025
3.7500	N/A	N/A	- .0008 - .0014	+ .0000 - .0006	+ .0000 - .0010	3.7525
4.5000	N/A	N/A	- .0008 - .0014	+ .0000 - .0006	+ .0000 - .0010	4.5025

## Guide Pins – Press Fit

TN and ATN pins are made of hardened steel with a precision-ground running diameter (D1), these guide pins are perfect mates for standard Lamina guide bushings.

GUIDE PIN – STRAIGHT					
PART NUMBER	D1 (in)	L1 (in)	PART NUMBER	D1 (in)	L1 (in)
TN-750-X-4	3/4	4	TN-125-X-7	1-1/4	7
TN-750-X-4-1/2		4-1/2	TN-125-X-7-1/2		7-1/2
TN-750-X-5		5	TN-125-X-8		8
TN-750-X-6		6	TN-125-X-8-1/2		8-1/2
TN-750-X-7		7	TN-125-X-9		9
TN-750-X-8		8	TN-125-X-9-1/2		9-1/2
TN-100-X-4		1	4		TN-125-X-10
TN-100-X-4-1/2	4-1/2		TN-125-X-11	11	
TN-100-X-5	5		TN-125-X-12	12	
TN-100-X-5-1/2	5-1/2		TN-150-X-5	5	
TN-100-X-6	6		TN-150-X-5-1/2	5-1/2	
TN-100-X-6-1/2	6-1/2		TN-150-X-6	6	
TN-100-X-7	7		TN-150-X-6-1/2	6-1/2	
TN-100-X-7-1/2	7-1/2		TN-150-X-7	7	
TN-100-X-8	8		TN-150-X-7-1/2	7-1/2	
TN-100-X-8-1/2	8-1/2		TN-150-X-8	8	
TN-100-X-9	1-1/4	9	TN-150-X-8-1/2	1-1/2	8-1/2
TN-100-X-10		10	TN-150-X-9		9
TN-125-X-4-1/2		4-1/2	TN-150-X-9-1/2		9-1/2
TN-125-X-5		5	TN-150-X-10		10
TN-125-X-5-1/2		5-1/2	TN-150-X-11		11
TN-125-X-6		6	TN-150-X-12		12
TN-125-X-6-1/2		6-1/2			

GUIDE PIN – STRAIGHT					
ATN-175-X-6	1-3/4	6	ATN-200-X-12	2	12
ATN-175-X-6-1/2		6-1/2	ATN-200-X-13		13
ATN-175-X-7		7	ATN-200-X-14		14
ATN-175-X-7-1/2		7-1/2	ATN-200-X-15		15
ATN-175-X-8		8	ATN-250-X-8		2-1/2
ATN-175-X-8-1/2		8-1/2	ATN-250-X-8-1/2	8-1/2	
ATN-175-X-9		9	ATN-250-X-9	9	
ATN-175-X-9-1/2		9-1/2	ATN-250-X-9-1/2	9-1/2	
ATN-175-X-10		10	ATN-250-X-10	10	
ATN-175-X-11		11	ATN-250-X-11	11	
ATN-175-X-12		12	ATN-250-X-12	12	
ATN-175-X-13		13	ATN-250-X-13	13	
ATN-175-X-14		14	ATN-250-X-14	14	
ATN-175-X-15		15	ATN-250-X-15	15	
ATN-200-X-6		2	6	ATN-300-X-9	3
ATN-200-X-6-1/2	6-1/2		ATN-300-X-10	10	
ATN-200-X-7	7		ATN-300-X-11	11	
ATN-200-X-7-1/2	7-1/2		ATN-300-X-12	12	
ATN-200-X-8	8		ATN-300-X-13	13	
ATN-200-X-8-1/2	8-1/2		ATN-300-X-14	14	
ATN-200-X-9	9		ATN-300-X-15	15	
ATN-200-X-10	10		ATN-300-X-17	17	
ATN-200-X-10-1/2	10-1/2		ATN-300-X-19	19	
ATN-200-X-11	11		ATN-300-X-21	21	

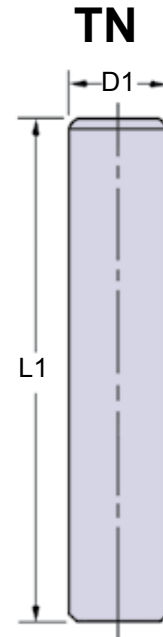

TN pins are centerless ground.

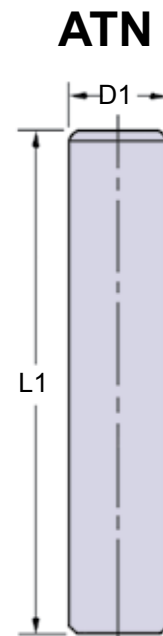

ATN pins are centerless ground.

Please see bore size information on page 18.

GUIDE PIN – STRAIGHT - PRESS FIT END UNGROUND															
PART NUMBER	D1 (in)	D2 (in)	L1 (in)	L2 (in)	PART NUMBER	D1 (in)	D2 (in)	L1 (in)	L2 (in)						
TPB-750-X-4	3/4	0.766 0.762	4	1-3/8	TPB-175-X-6	1-3/4	1.766 1.762	6	2-1/4						
TPB-750-X-4-1/2			4-1/2		TPB-175-X-6-1/2			6-1/2							
TPB-750-X-5			5		TPB-175-X-7			7							
TPB-750-X-5-1/2			5-1/2		TPB-175-X-7-1/2			7-1/2							
TPB-750-X-6			6		TPB-175-X-8			8							
TPB-750-X-7			7		TPB-175-X-8-1/2			8-1/2							
TPB-750-X-7-1/2			7-1/2		TPB-175-X-9			9							
TPB-750-X-8			8		TPB-175-X-9-1/2			9-1/2							
TPB-100-X-4			1		1.016 1.012			4		1-1/2	TPB-175-X-10	2	2.016 2.012	10	2-1/2
TPB-100-X-4-1/2								4-1/2			TPB-175-X-11			11	
TPB-100-X-5	5	TPB-175-X-12		12											
TPB-100-X-5-1/2	5-1/2	TPB-175-X-13		13											
TPB-100-X-6	6	TPB-175-X-14		14											
TPB-100-X-6-1/2	6-1/2	TPB-175-X-15		15											
TPB-100-X-7	7	TPB-175-X-17		17											
TPB-100-X-7-1/2	7-1/2	TPB-200-X-6		6											
TPB-100-X-8	8	TPB-200-X-6-1/2		6-1/2											
TPB-100-X-8-1/2	8-1/2	TPB-200-X-7		7											
TPB-100-X-9	9	TPB-200-X-7-1/2	7-1/2												
TPB-100-X-10	10	TPB-200-X-8	8												
TPB-125-X-4	1-1/4	1.266 1.262	4	1-3/4	TPB-200-X-8-1/2	2	2.016 2.012	8-1/2	2-1/2						
TPB-125-X-4-1/2			4-1/2		TPB-200-X-9			9							
TPB-125-X-5			5		TPB-200-X-9-1/2			9-1/2							
TPB-125-X-5-1/2			5-1/2		TPB-200-X-10			10							
TPB-125-X-6			6		TPB-200-X-11			11							
TPB-125-X-6-1/2			6-1/2		TPB-200-X-12			12							
TPB-125-X-7			7		TPB-200-X-13			13							
TPB-125-X-7-1/2			7-1/2		TPB-200-X-14			14							
TPB-125-X-8			8		TPB-200-X-15			15							
TPB-125-X-8-1/2			8-1/2		TPB-200-X-17			17							
TPB-125-X-9			9		TPB-200-X-19			19							
TPB-125-X-9-1/2			9-1/2		TPB-250-X-8			8							
TPB-125-X-10	10	TPB-250-X-8-1/2	8-1/2												
TPB-125-X-11	11	TPB-250-X-9	9												
TPB-125-X-12	12	TPB-250-X-10	10												
TPB-150-X-4-1/2	1-1/2	1.516 1.512	4-1/2	2	TPB-250-X-11	2-1/2	2.516 2.512	11	3-1/2						
TPB-150-X-5			5		TPB-250-X-12			12							
TPB-150-X-5-1/2			5-1/2		TPB-250-X-13			13							
TPB-150-X-6			6		TPB-250-X-14			14							
TPB-150-X-6-1/2			6-1/2		TPB-250-X-15			15							
TPB-150-X-7			7		TPB-250-X-17			17							
TPB-150-X-7-1/2			7-1/2		TPB-250-X-19			19							
TPB-150-X-8			8		TPB-250-X-21			21							
TPB-150-X-8-1/2			8-1/2		TPB-300-X-9			9							
TPB-150-X-9			9		TPB-300-X-10			10							
TPB-150-X-9-1/2			9-1/2		TPB-300-X-11			11							
TPB-150-X-10			10		TPB-300-X-12			12							
TPB-150-X-11			11		TPB-300-X-13			13							
TPB-150-X-12			12		TPB-300-X-14			14							
TPB-150-X-13			13		TPB-300-X-15			15							
TPB-150-X-14			14		TPB-300-X-17			17							
TPB-150-X-15			15		TPB-300-X-19			19							
TPB-150-X-18			18		TPB-300-X-21			21							

## Guide Pins – Press Fit

TPB

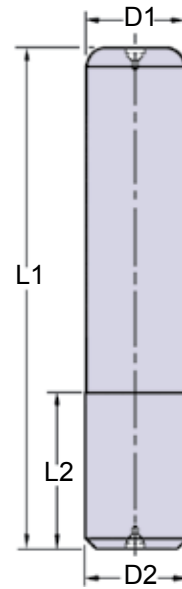

All TPB Guide Pins have centers and stock left on the D2 diameter for grinding.

See bore size information on page 18.

<b>PART NUMBER</b>	<b>TPB-375-X</b>
3-3/4" diameters L1 & L2 lengths as specified	
<b>PART NUMBER</b>	<b>TPB-450-X</b>
4-1/2" diameters L1 & L2 lengths as specified	
Call for quotation on pins above.	



**GUIDE PIN STRAIGHT – PRESS FIT GROUND**

PART NUMBER	D1 (in)	L1 (in)	L2 (in)	PART NUMBER	D1 (in)	L1 (in)	L2 (in)	PART NUMBER	D1 (in)	L1 (in)	L2 (in)
TPC-750-X-4	3/4	4	1-3/8	TPC-150-X-8	1-1/2	8	2	TPC-300-X-9	3	9	4
TPC-750-X-4-1/2		4-1/2		TPC-150-X-8-1/2		8-1/2		TPC-300-X-10		10	
TPC-750-X-5		5		TPC-150-X-9		9		TPC-300-X-11		11	
TPC-750-X-5-1/2		5-1/2		TPC-150-X-9-1/2		9-1/2		TPC-300-X-12		12	
TPC-750-X-6		6		TPC-150-X-10		10		TPC-300-X-13		13	
TPC-750-X-6-1/2		6-1/2		TPC-150-X-11		11		TPC-300-X-14		14	
TPC-750-X-7		7		TPC-150-X-12		12		TPC-300-X-15		15	
TPC-750-X-7-1/2		7-1/2		TPC-175-X-6		6		TPC-300-X-17		17	
TPC-750-X-8		8		TPC-175-X-6-1/2		6-1/2		TPC-300-X-19		19	
TPC-875-X-4		7/8		4		1-1/2		TPC-175-X-7		1-3/4	
TPC-875-X-4-1/2	4-1/2		TPC-175-X-7-1/2	7-1/2							
TPC-875-X-5	5		TPC-175-X-8	8							
TPC-875-X-5-1/2	5-1/2		TPC-175-X-8-1/2	8-1/2							
TPC-875-X-6	6		TPC-175-X-9	9							
TPC-875-X-6-1/2	6-1/2		TPC-175-X-9-1/2	9-1/2							
TPC-875-X-7	7		TPC-175-X-10	10							
TPC-875-X-7-1/2	7-1/2		TPC-175-X-11	11							
TPC-875-X-8	8		TPC-175-X-12	12							
TPC-100-X-4	1		4	1-1/2	TPC-175-X-13		2	13	2-1/2		
TPC-100-X-4-1/2		4-1/2	TPC-175-X-14		14						
TPC-100-X-5		5	TPC-175-X-15		15						
TPC-100-X-5-1/2		5-1/2	TPC-175-X-17		17						
TPC-100-X-6		6	TPC-200-X-6		6						
TPC-100-X-6-1/2		6-1/2	TPC-200-X-6-1/2		6-1/2						
TPC-100-X-7		7	TPC-200-X-7		7						
TPC-100-X-7-1/2		7-1/2	TPC-200-X-7-1/2		7-1/2						
TPC-100-X-8		8	TPC-200-X-8		8						
TPC-100-X-8-1/2		8-1/2	TPC-200-X-8-1/2		8-1/2						
TPC-100-X-9	9	TPC-200-X-9	9								
TPC-100-X-10	10	TPC-200-X-9-1/2	9-1/2								
TPC-125-X-4	1-1/4	4	1-3/4	TPC-200-X-10	2-1/2	10	3-1/2				
TPC-125-X-4-1/2		4-1/2		TPC-200-X-11		11					
TPC-125-X-5		5		TPC-200-X-12		12					
TPC-125-X-5-1/2		5-1/2		TPC-200-X-13		13					
TPC-125-X-6		6		TPC-200-X-14		14					
TPC-125-X-6-1/2		6-1/2		TPC-200-X-15		15					
TPC-125-X-7		7		TPC-200-X-17		17					
TPC-125-X-7-1/2		7-1/2		TPC-200-X-19		19					
TPC-125-X-8		8		TPC-250-X-8		8					
TPC-125-X-8-1/2		8-1/2		TPC-250-X-8-1/2		8-1/2					
TPC-125-X-9	9	TPC-250-X-9	9								
TPC-125-X-9-1/2	9-1/2	TPC-250-X-10	10								
TPC-125-X-10	10	TPC-250-X-11	11								
TPC-125-X-11	11	TPC-250-X-12	12								
TPC-125-X-12	12	TPC-250-X-13	13								
TPC-150-X-4-1/2	1-1/2	4-1/2	2	TPC-250-X-14	2-1/2	14	3-1/2				
TPC-150-X-5		5		TPC-250-X-15		15					
TPC-150-X-5-1/2		5-1/2		TPC-250-X-17		17					
TPC-150-X-6		6		TPC-250-X-19		19					
TPC-150-X-6-1/2		6-1/2		TPC-250-X-21		21					
TPC-150-X-7		7									
TPC-150-X-7-1/2		7-1/2									

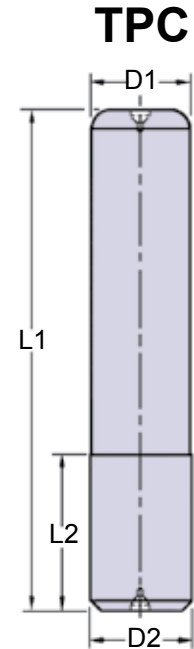

D2 Specifications:

TPC-100 & smaller = nominal plus .0020 <sup>+0.000</sup><sub>-0.006</sub>

TPC-125 - 300 = nominal plus .0025 <sup>+0.000</sup><sub>-0.008</sub>

TPC-375 & 450 = nominal plus .0025 <sup>+0.000</sup><sub>-0.010</sub>

<b>PART NUMBER</b>	<b>TPC-375-X</b>
3-3/4" diameters L1 & L2 lengths as specified	
<b>PART NUMBER</b>	<b>TPC-450-X</b>
4-1/2" diameters L1 & L2 lengths as specified	
Call for quotation on pins above.	

Not all pins ground on centers.

# Guide Pins – Press Fit – Metric Solid & Hollow

These pins are made especially for automotive stamping companies. They conform to the standards agreed to by the North American Automotive Metric Standards group.

*AUTOMOTIVE METRIC*  
**NAAMS** STANDARD

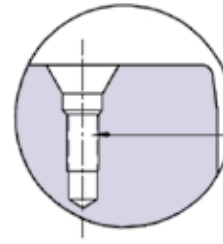

32, 40, 50 & 63  
Dia. guide posts  
have M8 x 1.25 -12  
thread; 80, 100,  
115 & 125 Dia.  
guide posts have  
M12 x 1.75 - 18  
thread to facilitate  
handling from deep  
freeze.

GUIDE PIN – STRAIGHT – NAAMS									
SOLID		HOLLOW	D1	D1 Tol g6	D2	D2 Tol r6	D4 Hollow Pins only	L1	L3
PART NUMBER	PART NUMBER	PART NUMBER							
GROUND	UNGROUND	GROUND							
G512512	G512512UG	N/A	25	- .007 - .020	25	+ .041 + .028	—	125	36
G512514	G512514UG							140	
G512516	G512516UG							160	
G512518	G512518UG							180	
G513214	G513214UG	N/A	32	- .009 - .025	32	+ .050 + .034	—	140	45
G513216	G513216UG							160	
G513218	G513218UG							180	
G513220	G513220UG							200	
G514014	G514014UG	N/A	40	- .009 - .025	40	+ .050 + .034	—	140	56
G514016	G514016UG							160	
G514018	G514018UG							180	
G514020	G514020UG							200	
G514022	G514022UG							225	
G514025	G514025UG							250	
G515016	G515016UG	N/A	50	- .009 - .025	50	+ .050 + .034	—	160	70
G515018	G515018UG							180	
G515020	G515020UG							200	
G515022	G515022UG							225	
G515025	G515025UG							250	
G515028	G515028UG							280	
G515031	G515031UG	N/A	63	- .010 - .029	63	+ .060 + .041	—	315	80
G516318	G516318UG							180	
G516320	G516320UG							200	
G516322	G516322UG							225	
G516325	G516325UG							250	
G516328	G516328UG							280	
G516331	G516331UG	N/A	80	- .010 - .029	80	+ .062 + .043	—	315	100
G516335	G516335UG							355	
G516340	G516340UG							400	
G516350	G516350UG							500	
G518022	G518022UG							225	
G518025	G518025UG							250	
G518028	G518028UG	280							
G518031	G518031UG	N/A	100	- .012 - .034	100	+ .073 + .051	50	315	125
G518035	G518035UG							355	
G518040	G518040UG							400	
G518045	G518045UG							450	
G518050	G518050UG							500	
G511031	G511031UG							GH511031	
G511035	G511035UG	GH511035	355						
G511040	G511040UG	GH511040	400						
G511045	G511045UG	GH511045	450						
G511050	G511050UG	GH511050	500						
G511055	G511055UG	GH511055	550						
G511060	G511060UG	GH511060	600						
G511065	G511065UG	—	650						
G511140	G511140UG	N/A	115	- .012 - .034	115	+ .076 + .054	—	400	140
G511150	G511150UG							500	
G511235	G511235UG	GH511235	355						
G511240	G511240UG	GH511240	400						
G511245	G511245UG	GH511245	450						
G511250	G511250UG	GH511250	500						
G511255	G511255UG	GH511255	550						
G511260	G511260UG	GH511260	600						
G511265	G511265UG	GH511265	650						
G511270	—	—	700						

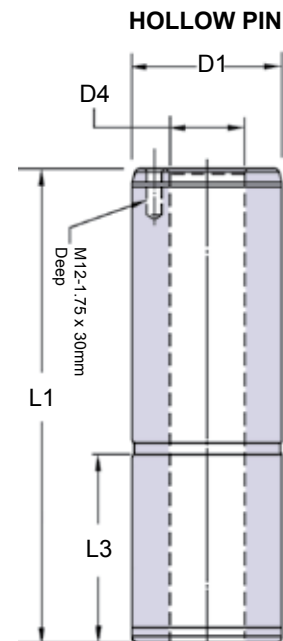
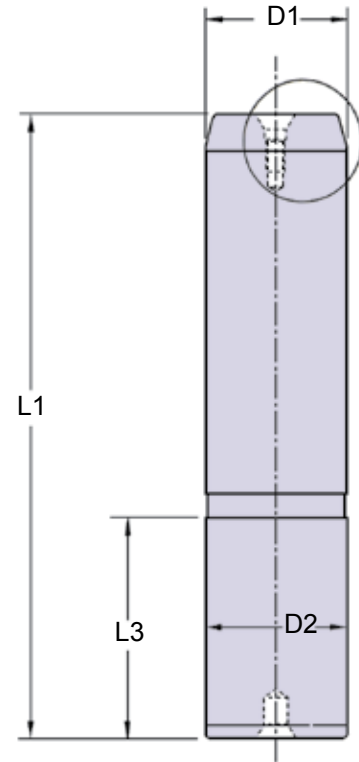

Please see bore size information on page 18.

## Guide Pins – Press Fit – Metric

GUIDE PINS – STRAIGHT – METRIC					
PART NUMBER	D1 (mm)	L1 (mm)	PART NUMBER	D1 (mm)	L1 (mm)
TN-19MM-X-120	19	120	TN-25MM-X-220	25	220
TN-19MM-X-130		130	TN-25MM-X-240		240
TN-19MM-X-140		140	TN-25MM-X-260		260
TN-19MM-X-150		150	TN-25MM-X-280		280
TN-19MM-X-160		160	TN-32MM-X-130	32	130
TN-19MM-X-170		170	TN-32MM-X-140		140
TN-19MM-X-180		180	TN-32MM-X-150		150
TN-19MM-X-190		190	TN-32MM-X-160		160
TN-19MM-X-200		200	TN-32MM-X-170		170
TN-25MM-X-120		25	120		TN-32MM-X-180
TN-25MM-X-130	130		TN-32MM-X-190		190
TN-25MM-X-140	140		TN-32MM-X-200		200
TN-25MM-X-150	150		TN-32MM-X-220		220
TN-25MM-X-160	160		TN-32MM-X-240		240
TN-25MM-X-170	170		TN-32MM-X-260	260	
TN-25MM-X-180	180		TN-32MM-X-280	280	
TN-25MM-X-190	190		TN-32MM-X-300	300	
TN-25MM-X-200	200				

**TN -Metric**

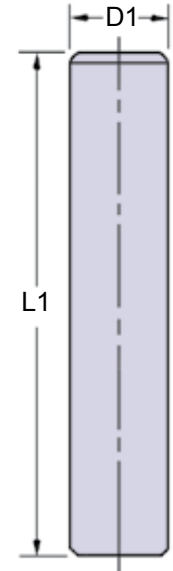

TN pins are designed to be pressed into place. The ground bearing surface is equal top to bottom.

STRAIGHT GUIDE PINS – METRIC – UNGROUND													
PART NUMBER	D1 (mm)	D2 (mm)	L1 (mm)	L2 (mm)	PART NUMBER	D1 (mm)	D2 (mm)	L1 (mm)	L2 (mm)				
TPB-40MM-X-130	40	40.65 40.15	130	50	TPB-50MM-X-260	50	50.65 50.15	260	60				
TPB-40MM-X-140			140		TPB-50MM-X-280			280					
TPB-40MM-X-150			150		TPB-50MM-X-300			300					
TPB-40MM-X-160			160		TPB-50MM-X-320			320					
TPB-40MM-X-170			170		TPB-50MM-X-360			360					
TPB-40MM-X-180			180		TPB-63MM-X-200			200					
TPB-40MM-X-190			190		TPB-63MM-X-220	220							
TPB-40MM-X-200			200		TPB-63MM-X-240	240							
TPB-40MM-X-220			220		TPB-63MM-X-260	260							
TPB-40MM-X-240			240		TPB-63MM-X-280	280							
TPB-40MM-X-260			260		TPB-63MM-X-300	300							
TPB-40MM-X-280			280		TPB-63MM-X-320	320							
TPB-40MM-X-300			300		TPB-63MM-X-360	360							
TPB-40MM-X-320			320		TPB-63MM-X-400	400							
TPB-40MM-X-360			360		TPB-63MM-X-440	440							
TPB-50MM-X-150			50		50.65 50.15	150	60	TPB-80MM-X-280		80	80.65 80.15	280	100
TPB-50MM-X-160						160		TPB-80MM-X-300				300	
TPB-50MM-X-170						170		TPB-80MM-X-320				320	
TPB-50MM-X-180	180	TPB-80MM-X-360		360									
TPB-50MM-X-190	190	TPB-80MM-X-400		400									
TPB-50MM-X-200	200	TPB-80MM-X-440		440									
TPB-50MM-X-220	220	TPB-80MM-X-500		500									
TPB-50MM-X-240	240												

**TPB - Metric**

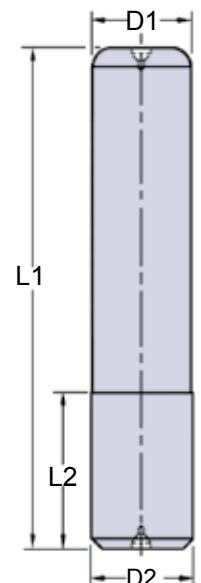

All TPB Guide Pins have centers and stock left on the D2 diameter for grinding.

## Guide Pins – Tap Fit

Lamina demountable guide pins are tap fit and require toe clamps and screws to hold them in place.

The clamping flange is ground so that the flange fits squarely against the mounting surface.

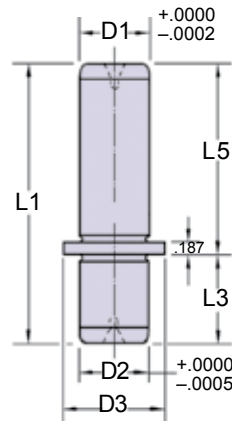

Heavy-duty X-40-Clamps are used to secure the pins to the die shoe.

Clamps and screws are included.

Please see pages 16 & 17 for toe clamp placement information and bore size information on page 18.

GUIDE PINS – DEMOUNTABLE													
PART NUMBER	D1 & D2 NOM. PIN DIA.	D3 +.000 - .015	L1 ± .010	L3 ± .010	L5 (Ref.)	# of CLAMPS	PART NUMBER	D1 & D2 NOM. PIN DIA.	D3 +.000 - .015	L1 ± .010	L3 ± .010	L5 (Ref.)	# of CLAMPS
DGP0810	1	1.313	3.688	1.188	2.500	3	DGP1032	1-1/4	1.563	9.188	1.188	8.000	3
DGP0811			3.938		2.750		DGP1033			9.438		8.250	
DGP0812			4.188		3.000		DGP1036			10.188		9.000	
DGP0813			4.438		3.250		DGP1037			10.438		9.250	
DGP0814			4.688		3.500		DGP1040			11.188		10.000	
DGP0815			4.938		3.750		DGP1041			11.438		10.250	
DGP0816			5.188		4.000		DGP1211			4.188		2.750	
DGP0817			5.438		4.250		DGP1212			4.438		3.000	
DGP0818			5.688		4.500		DGP1213			4.688		3.250	
DGP0819			5.938		4.750		DGP1214			4.938		3.500	
DGP0820			6.188		5.000		DGP1215			5.188		3.750	
DGP0822			6.688		5.500		DGP1216			5.438		4.000	
DGP0824			7.188		6.000		DGP1217			5.688		4.250	
DGP0826			7.688		6.500		DGP1218			5.938		4.500	
DGP0828			8.188		7.000		DGP1219			6.188		4.750	
DGP0830			8.688		7.500		DGP1220			6.438		5.000	
DGP0832	9.188	8.000	DGP1221	6.688	5.250								
DGP1011	1-1/4	1.563	3.938	1.188	2.750	3	DGP1222	1-1/2	1.875	6.938	1.438	5.500	3
DGP1012			4.188		3.000		DGP1223			7.188		5.750	
DGP1013			4.438		3.250		DGP1224			7.438		6.000	
DGP1014			4.688		3.500		DGP1225			7.688		6.250	
DGP1015			4.938		3.750		DGP1226			7.938		6.500	
DGP1016			5.188		4.000		DGP1227			8.188		6.750	
DGP1017			5.438		4.250		DGP1228			8.438		7.000	
DGP1018			5.688		4.500		DGP1229			8.688		7.250	
DGP1019			5.938		4.750		DGP1230			8.938		7.500	
DGP1020			6.188		5.000		DGP1232			9.438		8.000	
DGP1021			6.438		5.250		DGP1233			9.688		8.250	
DGP1022			6.688		5.500		DGP1236			10.438		9.000	
DGP1023			6.938		5.750		DGP1237			10.688		9.250	
DGP1024			7.188		6.000		DGP1240			11.438		10.000	
DGP1025			7.438		6.250		DGP1241			11.688		10.250	
DGP1026			7.688		6.500		DGP1414			5.188		3.500	
DGP1027	7.938	6.750	DGP1416	5.688	4.000								
DGP1028	8.188	7.000	DGP1417	5.938	4.250								
DGP1029	8.438	7.250	DGP1418	6.188	4.500								
DGP1030	8.688	7.500	DGP1419	6.438	4.750								

# Guide Pins – Tap Fit

Lamina demountable guide pins are tap fit and require toe clamps and screws to hold them in place.

The clamping flange is ground so that the flange fits squarely against the mounting surface.

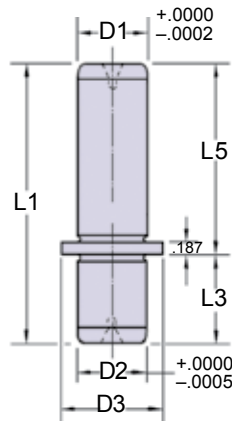

Heavy-duty X-40-Clamps are used to secure the pins to the die shoe.

Clamps and screws are included.

Please see pages 16 & 17 for toe clamp placement information and bore size information on page 18.

GUIDE PINS – DEMOUNTABLE													
PART NUMBER	D1 & D2 NOM. PIN DIA.	D3 + .000 - .015	L1 ± .010	L3 ± .010	L5 (Ref.)	# of CLAMPS	PART NUMBER	D1 & D2 NOM. PIN DIA.	D3 + .000 - .015	L1 ± .010	L3 ± .010	L5 (Ref.)	# of CLAMPS
DGP1420	1-3/4	2.250	6.688	1.688	5.000	4	DGP2022	2-1/2	3.031	7.438	1.938	5.500	4
DGP1422			7.188		5.500		DGP2024			7.938		6.000	
DGP1424			7.688		6.000		DGP2026			8.438		6.500	
DGP1426			8.188		6.500		DGP2028			8.938		7.000	
DGP1428			8.688		7.000		DGP2030			9.438		7.500	
DGP1430			9.188		7.500		DGP2032			9.938		8.000	
DGP1432			9.688		8.000		DGP2034			10.438		8.500	
DGP1434			10.188		8.500		DGP2036			10.938		9.000	
DGP1436			10.688		9.000		DGP2038			11.438		9.500	
DGP1438			11.188		9.500		DGP2040			11.938		10.000	
DGP1440			11.688		10.000		DGP2042			12.438		10.500	
DGP1446			13.188		11.500		DGP2048			13.938		12.000	
DGP1448			13.688		12.000		DGP2054			15.438		13.500	
DGP1614			2		2.500		5.438			1.938		3.500	
DGP1616	5.938	4.000		DGP2064		17.938	16.000						
DGP1617	6.188	4.250		DGP2066		18.438	16.500						
DGP1618	6.438	4.500		DGP2418		6.938	4.500						
DGP1619	6.688	4.750		DGP2420		7.438	5.000						
DGP1620	6.938	5.000		DGP2422		7.938	5.500						
DGP1622	7.438	5.500		DGP2424		8.438	6.000						
DGP1624	7.938	6.000		DGP2426		8.938	6.500						
DGP1626	8.438	6.500		DGP2428		9.438	7.000						
DGP1628	8.938	7.000		DGP2430		9.938	7.500						
DGP1630	9.438	7.500		DGP2432		10.438	8.000						
DGP1632	9.938	8.000		DGP2434		10.938	8.500						
DGP1634	10.438	8.500		DGP2436		11.438	9.000						
DGP1636	10.938	9.000		DGP2438		11.938	9.500						
DGP1638	11.438	9.500		DGP2440		12.438	10.000						
DGP1640	11.938	10.000		DGP2442		12.938	10.500						
DGP1642	12.438	10.500		DGP2448		14.438	12.000						
DGP1646	13.438	11.500		DGP2454		15.938	13.500						
DGP1648	13.938	12.000		DGP2456		16.438	14.000						
DGP1656	15.938	14.000		DGP2464		18.438	16.000						
DGP1658	16.438	14.500	DGP2466	18.938	16.500								
DGP1670	19.438	17.500											
DGP2018	2-1/2	3.031	6.438	1.938	4.500	4							
DGP2020			6.938		5.000								

## Guide Pins – Press Fit

Shoulder type guide pins are for use with automotive, hardware, forming, or draw dies where stamping stock is thicker than 1/16", and clearances between punch and die sections will be more than .003" per side.

Shoulder type guide pins are also valuable for repair of damaged dies where straight type pins no longer fit.

(Pins available in Class 2)

GUIDE PINS – WITH SHOULDERS													
PART NUMBER	D1 NOM. PIN DIA. (in)	D2 PRESS DIA. (in)	L1 LENGTH (in)	L2 (in)	PART NUMBER	D1 NOM. PIN DIA. (in)	D2 PRESS DIA. (in)	L1 LENGTH (in)	L2 (in)				
HP-100-X-5-1/2	1	1-1/2	5-1/2	1-1/2	HP-200-X-8	2	2-1/2	8	3-1/2				
HP-100-X-6			6		HP-200-X-8-1/2			8-1/2					
HP-100-X-6-1/2			6-1/2		HP-200-X-9			9					
HP-100-X-7			7		HP-200-X-10			10					
HP-100-X-8			8		HP-200-X-11			11					
HP-100-X-9			9		HP-200-X-12			12					
HP-125-X-6	1-1/4	1-3/4	6	2	HP-200-X-13			2-1/2		3	13	4	
HP-125-X-7			7		HP-200-X-14						14		
HP-125-X-7-1/2			7-1/2		HP-200-X-15						15		
HP-125-X-8			8		HP-200-X-17						17		
HP-125-X-9			9		HP-250-X-9						9		
HP-150-X-6			1-1/2		2						6		2-1/2
HP-150-X-6-1/2	6-1/2	HP-250-X-11		11									
HP-150-X-7	7	HP-250-X-12		12									
HP-150-X-7-1/2	7-1/2	HP-250-X-13		13									
HP-150-X-8	8	HP-250-X-14		14									
HP-150-X-8-1/2	8-1/2	HP-250-X-15		15									
HP-150-X-9	9	HP-250-X-17		17									
HP-150-X-10	10	HP-300-X-11		11									
HP-150-X-11	11	HP-300-X-12		12									
HP-150-X-12	12	HP-300-X-14		14									
HP-150-X-13	13	HP-300-X-15		15									
HP-150-X-14	14	HP-300-X-17		17									
HP-175-X-7-1/2	1-3/4	2-1/4		7-1/2		3	HP-300RA-X-11	3	3-1/2	11	5		
HP-175-X-8				8			HP-300RA-X-12			12			
HP-175-X-9			9	HP-300RA-X-13	13								
HP-175-X-10			10	HP-300RA-X-14	14								
HP-175-X-11			11	HP-300RA-X-15	15								
HP-175-X-12			12	HP-300RA-X-17	17								
HP-175-X-13			13										
HP-175-X-14			14										

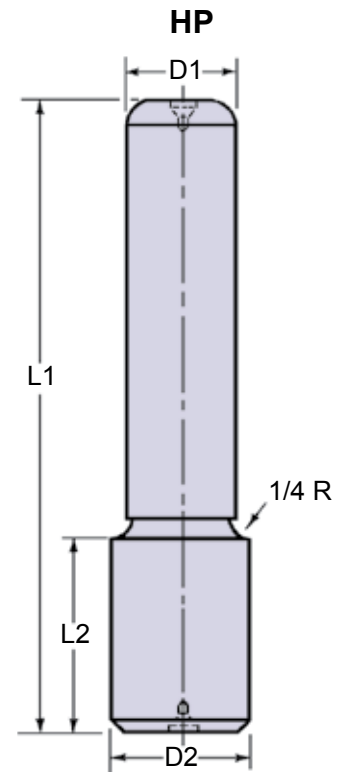

D2 dimension is supplied with approximately .016" grindstock.

HP Shoulder pins are meant to be press fit into place.

HP Pins can be manufactured in 3<sup>3</sup>/<sub>4</sub>" and 4<sup>1</sup>/<sub>2</sub>" diameters in various lengths. See page 22.

## Guide Pins – Tap Fit – Metric

Lamina has a wide variety of pins to meet most tool room requirements.

### Applications:

- Transfer Presses
- Repairs

*AUTOMOTIVE METRIC  
NAAMS STANDARD*

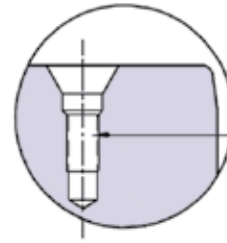

32, 40, 50 & 63 Dia. guide posts have M8 x 1.25 -12 thread; 80, 100, 115 & 125 Dia. guide posts have M12 x 1.75 - 18 thread to facilitate handling from deep freeze.

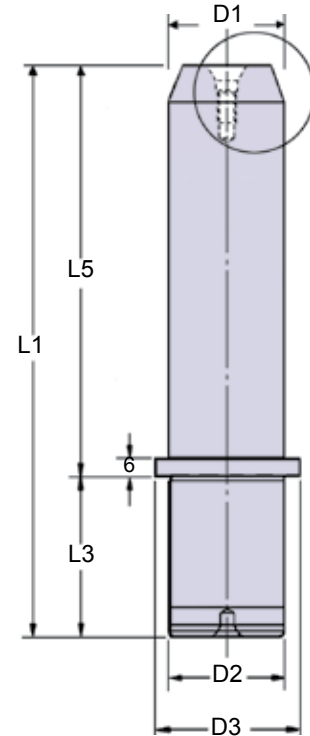

Must be held in place with toe clamps. Three G720000C toe clamps & screws are included.

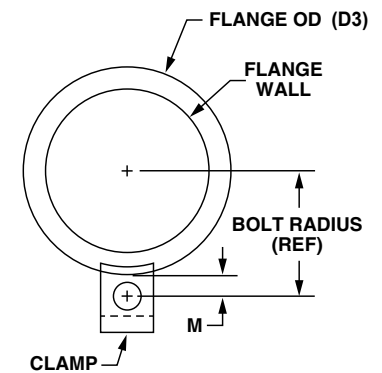

M = Flange OD to Clamp Bolt Center  
Bolt Radius = (Flange OD ÷ 2) + M

GUIDE PINS – WITH SHOULDERS – METRIC										
PART NUMBER	D1 (mm)	D1 TOL g6 (mm)	D2 (mm)	D2 TOL r6 (mm)	D3 (mm)	M	Bolt Radius (REF)	L1 (mm)	L3 (mm)	L5 (mm)
G503214	32	-.009 -.025	32	+.050 +.034	40	9	29	140	45	95
G503216								160		115
G503218								180		135
G503220								200		155
G504016	40	-.009 -.025	40	+.050 +.034	50	9	34	160	56	104
G504018								180		124
G504020								200		144
G504022								225		169
G504025								250		194
G505016	50	-.009 -.025	50	+.050 +.034	63	9	40.5	160	70	90
G505018								180		110
G505020								200		130
G505022								225		155
G505025								250		180
G505028								280		210
G505031								315		245
G506320	63	-.010 -.029	63	+.060 +.041	80	9	49	200	80	120
G506322								225		145
G506325								250		170
G506328								280		200
G506331								315		235
G506335								355		275
G506340								400		320
G508025	80	-.010 -.029	80	+.062 +.043	100	9	59	250	100	150
G508028								280		180
G508031								315		215
G508035								355		255
G508040								400		300
G501031	100	-.012 -.034	100	+.073 +.051	125	9	71.5	315	125	190
G501035								355		230
G501040								400		275

See pages 16 & 17 for clamping information; bore size information on page 18.

## Guide Pins – Removable Press Fit Bushing Liner

Designed specifically for all dies where it is desirable to remove pins for ease and simplicity of sharpening die.

Lamina removable pins are generally used with carbide dies, progressive dies, lamination dies, and dies for very thin materials where clearances between punch and die sections will be no more than .0007" per side.

Can be used with Plain Bearing & Keyless Ball-Bearing Bushing and Retainers.

GUIDE PIN – REMOVABLE							
PART NUMBER	D1 Nom. Pin Dia.	L1 Length	L2	Tapped Hole			
RP-100-X-5	1.0000 + .0001 - .0001	5.000	1.500	Pin End 5/16 – 18x3/4  Install End 5/16 – 18			
RP-100-X-5-1/2		5.500					
RP-100-X-6		6.000					
RP-100-X-6-1/2		6.500					
RP-100-X-7		7.000					
RP-100-X-7-1/2		7.500					
RP-100-X-8		8.000					
RP-100-X-8-1/2		8.500					
RP-100-X-9		9.000					
RP-125-X-5-1/2	1.2500 + .0001 - .0002	5.500	1.750	Pin End 5/16 – 18x7/8  Install End 3/8 – 16			
RP-125-X-6		6.000					
RP-125-X-6-1/2		6.500					
RP-125-X-7		7.000					
RP-125-X-7-1/2		7.500					
RP-125-X-8		8.000					
RP-125-X-8-1/2		8.500					
RP-125-X-9		9.000					
RP-125-X-10		10.000					
RP-125-X-11		11.000					
RP-125-X-12		12.000					
RP-125-X-13		13.000					
RP-125-X-14		14.000					
RP-150-X-5-1/2		1.5000 + .0001 - .0002			5.500	2.000	Pin End 3/8 – 16x1  Install End 3/8 – 16
RP-150-X-6	6.000						
RP-150-X-6-1/2	6.500						
RP-150-X-7	7.000						
RP-150-X-7-1/2	7.500						
RP-150-X-8	8.000						
RP-150-X-8-1/2	8.500						
RP-150-X-9	9.000						
RP-150-X-10	10.000						
RP-175-X-7	1.7500 + .0001 - .0002		7.000	2.250	Pin End 3/8 – 16x1  Install End 3/8 – 16		
RP-175-X-7-1/2		7.500					
RP-175-X-8		8.000					
RP-175-X-8-1/2		8.500					
RP-175-X-9		9.000					
RP-175-X-10	10.000						
RP-200-X-6	2.000 + .0001 - .0003	6.000	2.500	Pin End 3/8 – 16x7/8  Install End 3/8 – 16			
RP-200-X-7		7.000					
RP-200-X-7-1/2		7.500					
RP-200-X-8		8.000					
RP-200-X-8-1/2		8.500					
RP-200-X-9		9.000					
RP-200-X-10		10.000					
RP-200-X-11		11.000					
RP-200-X-12		12.000					
RP-200-X-13		13.000					
RP-200-X-14		14.000					
RP-250-X-9		2.500 + .0001 - .0003			9.000	3.500	Pin End 1/2 – 13x1  Install End 1/2 – 13
RP-250-X-10					10.000		
RP-250-X-11					11.000		
RP-250-X-12	12.000						
RP-250-X-13	13.000						
RP-250-X-14	14.000						
RP-300-X-	3.000	Non-stock, call for quotation.					

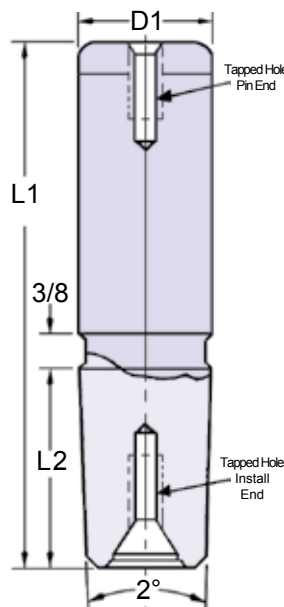

REMOVABLE PIN

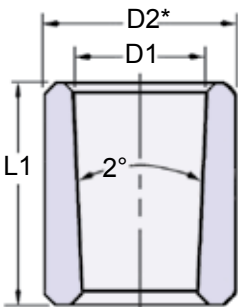

BUSHING LINER

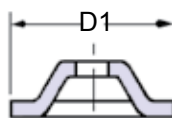

END CAP

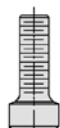

SOCKET HEAD CAP SCREW

ASSEMBLIES FOR REMOVABLE PINS		
PART NUMBER		D1 Nom Pin Diam.
GROUND	UNGROUND	
GRP-100-ASSY	RP-100-ASSY	1.000
GRP-125-ASSY	RP-125-ASSY	1.250
GRP-150-ASSY	RP-150-ASSY	1.500
GRP-175-ASSY	RP-175-ASSY	1.750
GRP-200-ASSY	RP-200-ASSY	2.000
GRP-250-ASSY	RP-250-ASSY	2.500
GRP-300-ASSY	RP-300-ASSY	3.000

Assembly includes 1 bushing liner, 1 End Cap & 1 Socket Head Cap Screw

BUSHING LINERS FOR REMOVABLE PINS				
PART NUMBER		D1 Nom Pin Diam.	D2* O.D.	L1 Length
GROUND	UNGROUND			
GNRB-100	NRB-100	1.000	1.5008 1.5006	1.625
GNRB-125	NRB-125	1.250	1.7508 1.7506	1.875
GNRB-150	NRB-150	1.500	2.0008 2.0006	2.125
GNRB-175	NRB-175	1.750	2.2508 2.2506	2.375
GNRB-200	NRB-200	2.000	2.5008 2.5006	2.625
GNRB-250	NRB-250	2.500	3.0008 3.0006	3.625
GNRB-300	NRB-300	3.000	3.5008 3.5006	4.125

\*.016 stock left on this diameter on unground liner for grinding to fit bored hole in die shoe

END CAPS FOR REMOVABLE PINS			
PART NUMBER	Nom Pin Diam.	D1 O.D.	Soc. Head Screw
RC-100-END-CAP	1.000	1.250	5/16-18x1
RC-125-END-CAP	1.250	1.500	3/8-16x1
RC-150-END-CAP	1.500	1.750	3/8-16x1
RC-175-END-CAP	1.750	2.000	3/8-16x1
RC-200-END-CAP	2.000	2.250	3/8-16x1
RC-250-END-CAP	2.500	2.880	1/2-13x1.5
RC-300-END-CAP	3.000	3.250	1/2-13x1.5

Removable pins, assemblies and screws are sold separately.



## SOLUTIONS TO FIT YOUR SPECIAL APPLICATIONS

In addition to “made to print” specials, a wide range of catalog components can be modified to meet customer specific applications. Round, flat, simple or complex, we want to make those one-of-a-kind parts for you.

At Lamina, our focus is on offering specials to you quickly and at a reasonable price.



Please send your prints and requests for quotation to [sales@lamina.com](mailto:sales@lamina.com).

## Stripper Bushings – Clamp & Press Fit Types

Lamina manufactures components specifically for use in dies where stripping operations take place such as in lamination dies. These components are made to “close tolerances.”

STRIPPER GUIDE PIN BUSHINGS – BRONZE-PLATED										
Assembly includes bushing, clamps and screws.										
PART NUMBER		Nom Pin Diam.	D1	D2	D3	D4	L1	L2	Bolt Circle Dia.	# of "D" Clamps
GROUND	UNGROUND*									
<b>GCG-75</b>	<b>CG-75</b>	3/4	0.7503 0.7502	1.1254 1.1252	1.125	1.313	1.625	1.000	1.719	2
<b>GCG-100</b>	<b>CG-100</b>	1	1.0003 1.0002	1.3754 1.3752	1.375	1.563	1.625	1.000	1.969	3

\* .016" grind stock on these diameters.

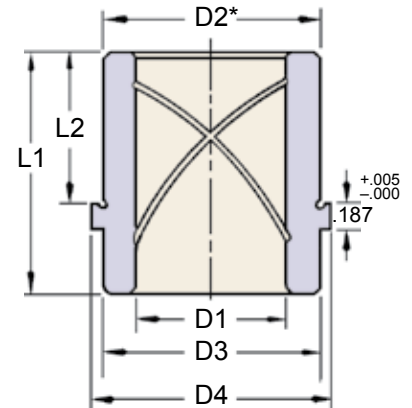

STRIPPER BUSHINGS – BRONZE PLATED PRESS FIT TYPE						
PART NUMBER		Nom Pin Diam.	D1	D2	D4 +.000 -.015	L1 +.000 -.031
GROUND	UNGROUND*					
<b>GHG-50</b>	<b>HG-50</b>	1/2	0.5003 0.5002	0.8754 0.8752	1.000	1
<b>GHG-62</b>	<b>HG-62</b>	5/8	0.6253 0.6252	1.0004 1.0002	1.125	1
<b>GHG-75</b>	<b>HG-75</b>	3/4	0.7503 0.7502	1.1254 1.1252	1.250	1
<b>GHG-100</b>	<b>HG-100</b>	1	1.0003 1.0002	1.3754 1.3752	1.500	1

\* .016" grind stock on these diameters.

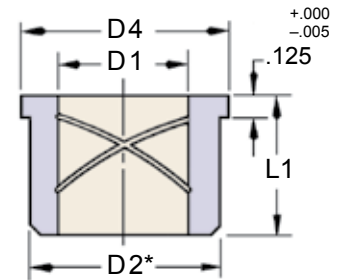

STRIPPER BUSHINGS – STRAIGHT TYPE					
PART NUMBER		Nom Pin Diam.	D1	D2	L
GROUND	UNGROUND*				
<b>GSG-100-L</b>	<b>SG-100-L</b>	1	1.0002 1.0004	1.3754 1.3752	2.375

\* .020" grind stock on these diameters.

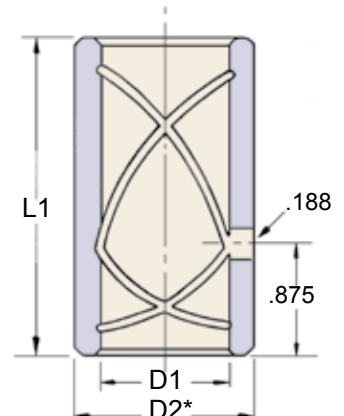

## Stripper Pins – Press Fit & Flange Types

STRIPPER PINS – PRESS FIT TYPE						
PART NUMBER	Nom. Pin Diam.	D1	D2*	L1	L2	L3
SGP-62-X-4	5/8	0.6250 0.6248	0.640	4.00	2.25	0.750
SGP-62-X-5	5/8	0.6250 0.6248	0.640	5.00	2.25	0.750
SGP-75-X-5	3/4	0.7500 0.7498	0.765	5.00	2.25	0.875
SGP-75-X-6-1/2	3/4	0.7500 0.7498	0.765	6.50	2.75	0.875
SGP-100-X-6-1/2	1	1.0000 0.9998	1.015	6.50	2.75	1.000
SGP-100-X-7-1/2	1	1.0000 0.9998	1.015	7.50	2.75	1.000

\* The D2 diameter is unground. Suggested finish grind size for D2 dimension to be .001 over nominal pin diameter.

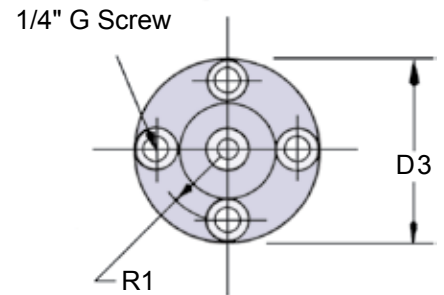
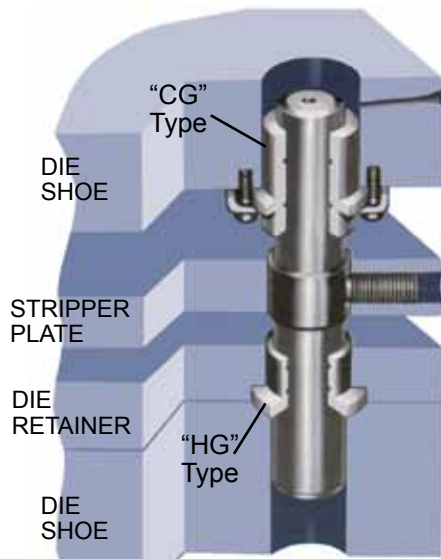
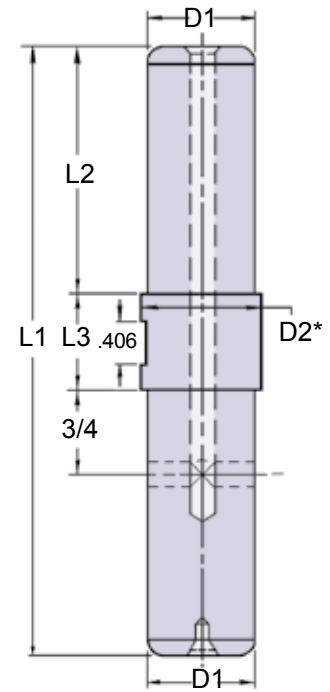

### STRIPPER PIN & BUSHING APPLICATION

STRIPPER PIN – FLANGE STYLE									
PART NUMBER	Nom. Pin Diam.	D1	D2* ± 0.003	D3	L1	L2	L3	R1	"G" Screws
F-8890	7/8	0.8750 0.8748	0.900	2.00	9.00	3.750	3.00	0.719	Flat Head
F-1080	1	1.0000 0.9998	1.025	2.00	8.00	3.500	1.50	0.750	Soc. Head
F-1085	1	1.0000 0.9998	1.025	2.00	8.50	3.500	1.50	0.750	Soc. Head
F-1090	1	1.0000 0.9998	1.025	2.00	9.00	3.500	1.50	0.750	Soc. Head
F-1290	1-1/4	1.2500 1.2498	1.275	2.25	9.00	3.500	1.50	0.875	Soc. Head

\* The D2 diameter is unground. Suggested finish bore size to be .005 over nominal pin diameter.

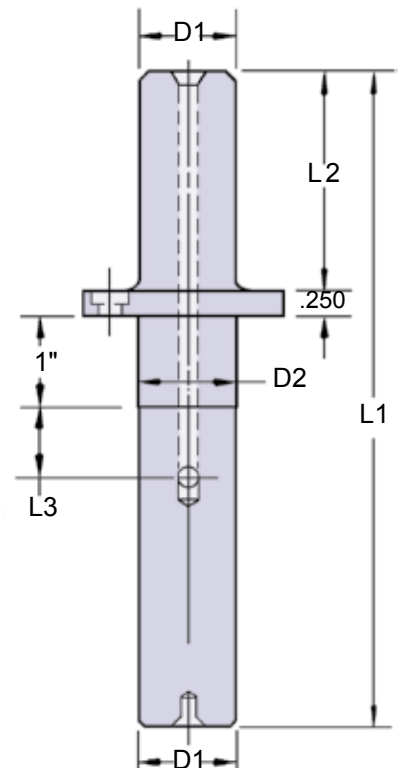

# Heavy Duty Stock Lifters

## MODEL 75 HARDENED, GROUND AND VENTED

Rockwell: RC 52-56  
Case Hardened .015 – .030 Deep

Packaged complete with spring, screw and retaining washer

When ordering please specify:

1. Quantity
2. Catalog Number

Lifters with travel greater than 1.75 are available. Priced on application. (Furnished without spring.)

### LIFTER SPECIFICATIONS

A – Operating Travel                      D – Pocket Depth for Spring  
B – Lifter Body Length                  E – Spring Free Length  
C – Pocket Depth for Lifter Body      F – Slot Length

MODEL 75 Stock Lifter O.D. .7495"  
(For Stock up to .094" thick)

LIFTER SPECIFICATIONS – MODEL 75								
PART NUMBER	A TRAVEL	B LIFTER LENGTH	C LIFTER POCKET	D SPRING POCKET	E SPRING FREE LENGTH	F SLOT LENGTH	REPLACE- MENT DIE SPRING	lbs. @ 1/10" SPRING DEFL.
75-50	0.50	2.312	2.50	2.938	2.50	1.000	M113L	4.5
75-75	0.75	2.562	2.75	3.938	3.50	1.250	M115L	3.0
75-1-0	1.00	2.812	3.00	4.938	4.50	1.500	M115AL	2.5
75-1-25	1.25	3.062	3.25	5.938	5.50	1.750	M115BL	2.1
75-1-50	1.50	3.312	3.50	6.938	6.50	2.000	M115CL	1.4
75-1-75	1.75	3.562	3.75	7.938	7.50	2.250	M115DL	1.2

Replacement Washer – #75WASHER  
Replacement Screw – #75SCREW  
Die Life Package – #DL75 (6 per package)

VALUES CONSTANT FOR ALL "75" LIFTERS		
a	.578	Dimension between CL of Lifter Pocket to CL of Socket Screw
b	.203	Slot Depth ± .005
c	.750	Pocket Diameter for Lifter Body + .001 / - .000
d	.688	Counter Bore Diameter for Lifter Washer
f	.25	Counter Bore Depth in Stripper Plate, minus half of stock thickness
g	.781	Counter Bore Diameter in Stripper Plate
h	.7495	Lifter Body Diameter + .0000 / - .0015
i	.125	Slot Height (for Stock) ± .005
j	.187	Dimension from Top of Slot to Top of Body ± .005
k	1.000	Length of Spring Pocket in Lifter Body
m	.50	Spring Pocket Diameter
n	1.125	Dimension from Bottom of Washer (Slot) to Bottom of Body
p	.375	Counter Bore Depth for Washer & Socket Screw

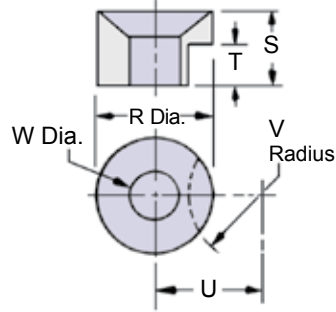

**PURPOSE**  
Available as Replacement Part No. DL75 Die Life Retaining Washer. 6 per package. Includes flat head socket screw 5/16-18x1.  
Note: In blanking die sections order optional Die Life "DL" Retaining Washers: Counterbore hole must be deeper.

DIE LIFE – REPLACEMENT RETAINING WASHER & SCREW KIT						
PART NUMBER	R	S	T	U	V	W
DL75	.656	.490	.280	.585	.390	.330

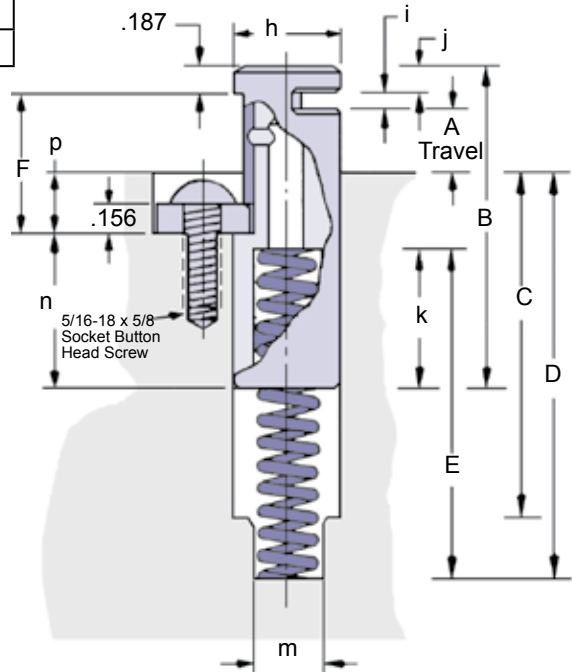
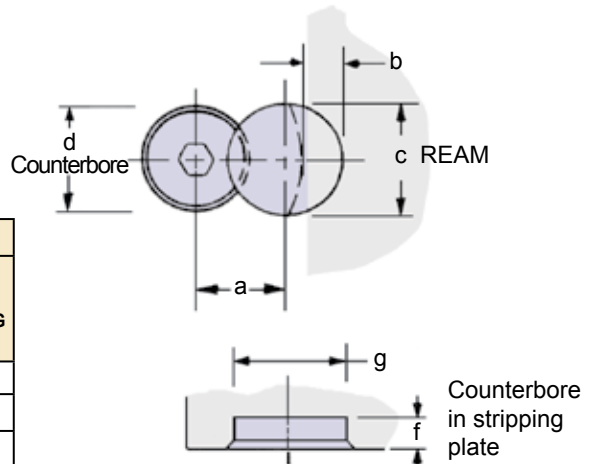

# Heavy Duty Stock Lifters

## MODEL 112 HARDENED, GROUND AND VENTED

Rockwell: RC 52-56  
Case Hardened .015 – .030 Deep

Packaged complete with spring, screw and retaining washer

When ordering please specify:

1. Quantity
2. Catalog Number

Lifters with travel greater than 1.75 are available. Priced on application. (Furnished without spring.)

### LIFTER SPECIFICATIONS

A – Operating Travel                      D – Pocket Depth for Spring  
B – Lifter Body Length                  E – Spring Free Length  
C – Pocket Depth for Lifter Body      F – Slot Length

MODEL 112 Stock Lifter O.D. 1.1245"  
(For Stock up to .156" thick)

LIFTER SPECIFICATIONS – MODEL 112								
PART NUMBER	A TRAVEL	B LIFTER LENGTH	C LIFTER POCKET	D SPRING POCKET	E SPRING FREE LENGTH	F SLOT LENGTH	REPLACE- MENT DIE SPRING	lbs. @ 1/10" SPRING DEFL.
112-50	0.50	2.812	2.625	3.063	2.50	1.250	M4L	12.0
112-75	0.75	3.062	2.875	4.063	3.50	1.500	M6L	8.0
112-1-0	1.00	3.312	3.125	5.063	4.50	1.750	M8L	6.4
112-1-25	1.25	3.562	3.375	6.063	5.50	2.000	M10L	5.5
112-1-50	1.50	3.812	3.625	7.063	6.50	2.250	M11BL	4.5
112-1-75	1.75	4.062	3.875	8.063	7.50	2.500	M11CL	3.8

Replacement Washer – #112 WASHER  
Replacement Screw – #112 SCREW  
Die Life Package – #DL112 (6 per package)

VALUES CONSTANT FOR ALL "112" LIFTERS		
a	.828	Dimension between CL of Lifter Pocket to CL of Socket Screw
b	.329	Slot Depth ± .005
c	1.125	Pocket Diameter for Lifter Body + .001 / - .000
d	.875	Counter Bore Diameter for Lifter Washer
f	.50	Counter Bore Depth in Stripper Plate, minus half of stock thickness
g	1.156	Counter Bore Diameter in Stripper Plate
h	1.1245	Lifter Body Diameter + .0000 / - .0015
i	.188	Slot Height (for Stock) ± .005
j	.406	Dimension from Top of Slot to Top of Body ± .005
k	1.125	Length of Spring Pocket in Lifter Body
m	.75	Spring Pocket Diameter
n	1.312	Dimension from Bottom of Washer (Slot) to Bottom of Body
p	.394	Counter Bore Depth for Washer & Socket Screw

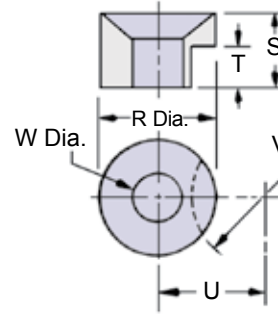

**PURPOSE**  
Available as Replacement Part No. DL112 Die Life Retaining Washer. 6 per package. Includes flat head socket screw 3/8-16x1-1/4. Note: In blanking die sections order optional Die Life "DL" Retaining Washers: Counterbore hole must be deeper.

DIE LIFE – REPLACEMENT RETAINING WASHER & SCREW KIT						
PART NUMBER	R	S	T	U	V	W
DL112	.840	.550	.300	.830	.580	.406

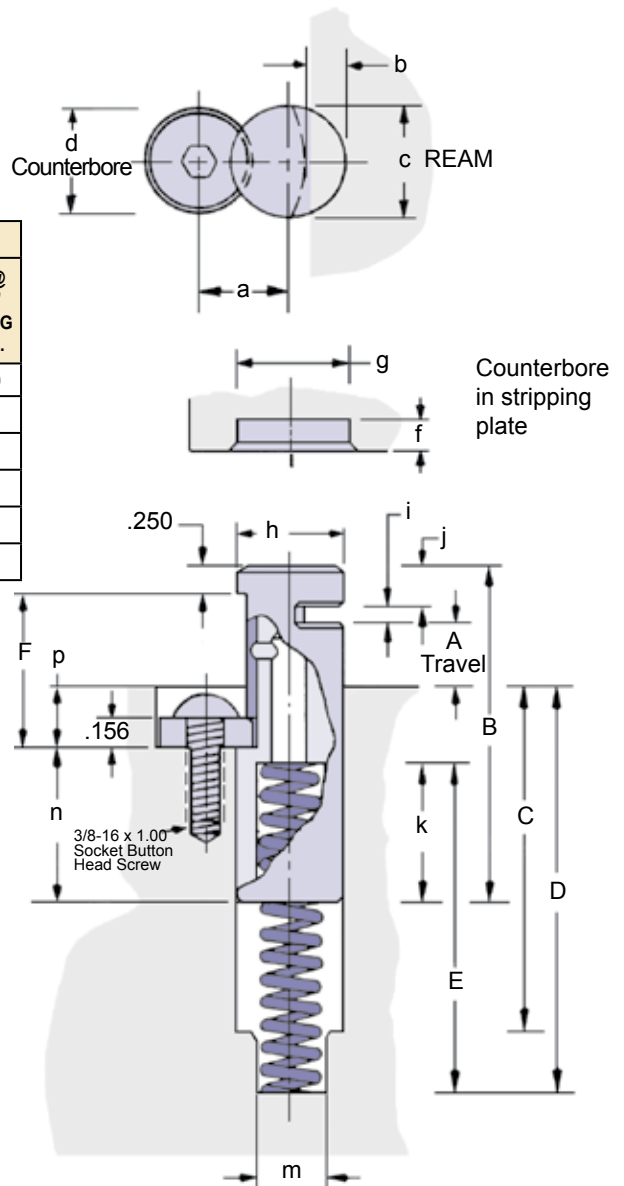

# Heavy Duty Rail Stock Lifter Pins

## MODEL T-750

### HARDENED, GROUND AND VENTED

Rockwell: RC 52-56

Case Hardened .015 – .030 Deep

Package complete with spring, screw and retaining washer.

When ordering please specify:

1. Quantity
2. Catalog Number

#### LIFTER SPECIFICATIONS

A – Operating Travel  
 B – Lifter Body Length  
 C – Pocket Depth for Lifter Body  
 D – Pocket Depth for Spring  
 E – Spring Free Length  
 F – Slot length  
 G – Top of Die to Top of Lifter Body

Rail Stock Lifter O.D. .7495" +.0000 –.0015

PART NUMBER	A TRAVEL	B LIFTER LENGTH	C & D LIFTER POCKET	G	E SPRING FREE LENGTH	F SLOT LENGTH	REPLACE- MENT DIE SPRING	lbs. @ 1/10" SPRING DEFL.
T-750-50	0.50	2.312	2.50	1.187	2.50	1.000	M113L	4.5
T-750-75	0.75	2.562	3.50	1.437	3.50	1.250	M115L	3.0
T-750-1-0	1.00	2.812	4.50	1.687	4.50	1.500	M115AL	2.5
T-750-1-25	1.25	3.062	5.50	1.937	5.50	1.750	M115BL	2.1
T-750-1-50	1.50	3.312	6.50	2.187	6.50	2.000	M115CL	1.4
T-750-1-75	1.75	3.562	7.50	2.437	7.50	2.250	M115DL	1.2

Replacement Washer Part Number – 75WASHER

Replacement Screw Part Number – 75SCREW

VALUES CONSTANT FOR ALL 75-T LIFTERS		
a	.578	Dimension between CL of Lifter Pocket to CL of Socket Screw
c	.750	Pocket Diameter for Lifter Body + .001 / - .000
d	.688	Counter Bore Diameter for Lifter Washer
h	.7495	Lifter Body Diameter + .0000 / - .0015
i	.125	Slot Height (for Stock) ± .005
j	.187	Dimension from Top of Slot to Top of Body ± .005
k	1.000	Length of Spring Pocket in Lifter Body
n	1.125	Dimension from Bottom of Washer (Slot) to Bottom of Body
p	.375	Counter Bore Depth for Washer & Socket Screw

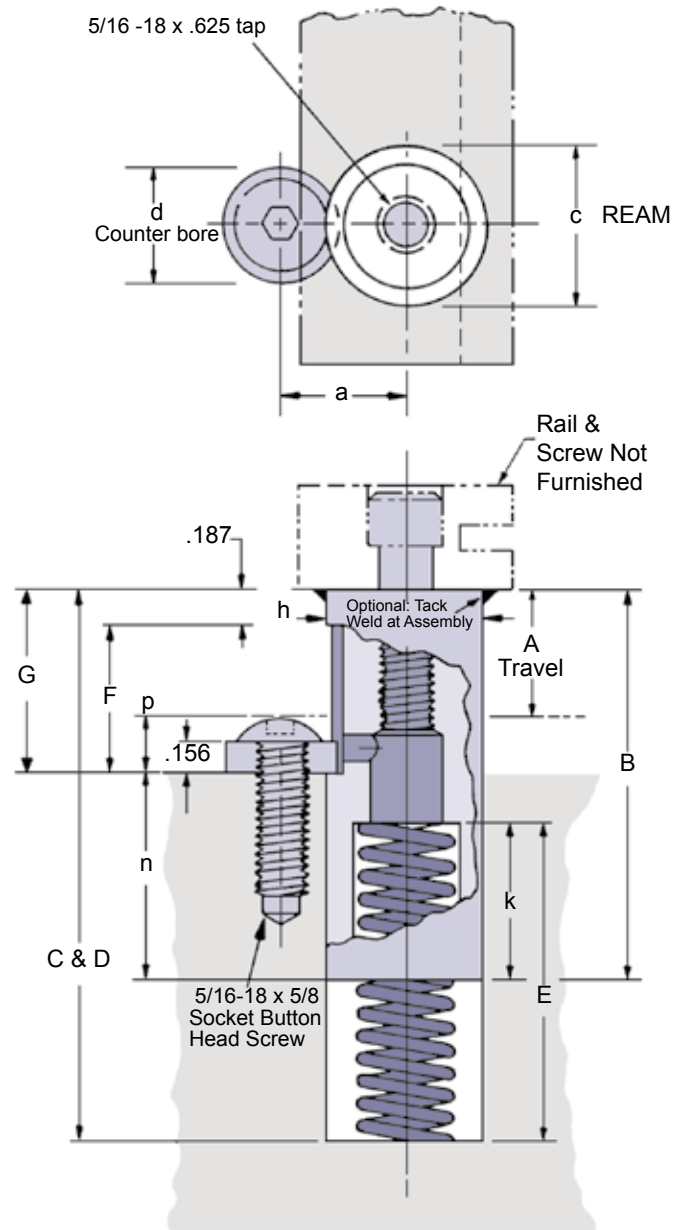

# Heavy Duty Rail Stock Lifter Pins

## MODEL 112T

### HARDENED, GROUND AND VENTED

Rockwell: RC 52-56

Case Hardened .015 – .030 Deep

Package complete with spring, screw and retaining washer.

When ordering please specify:

1. Quantity
2. Catalog Number

#### LIFTER SPECIFICATIONS

A – Operating Travel  
 B – Lifter Body Length  
 C – Pocket Depth for Lifter Body  
 D – Pocket Depth for Spring  
 E – Spring Free Length  
 F – Slot length  
 G – Top of Die to Top of Lifter Body

Rail Stock Lifter O.D. 1.1245" +.0000 –.0015

PART NUMBER	A TRAVEL	B LIFTER LENGTH	C & D LIFTER POCKET	G	E SPRING FREE LENGTH	F SLOT LENGTH	REPLACE- MENT DIE SPRING	lbs. @ 1/10" SPRING DEFL.
112T-50	0.50	2.812	2.562	1.500	2.50	1.250	M4L	12.0
112T-75	0.75	3.062	3.562	1.750	3.50	1.500	M6L	8.0
112T-1-00	1.00	3.312	4.562	2.000	4.50	1.750	M8L	6.4
112T-1-25	1.25	3.562	5.562	2.250	5.50	2.000	M10L	5.5
112T-1-50	1.50	3.812	6.562	2.500	6.50	2.250	M11BL	4.5
112T-1-75	1.75	4.062	7.562	2.750	7.50	2.500	M11CL	3.8

Replacement Washer Part Number – 112WASHER

Replacement Screw Part Number – 112SCREW

VALUES CONSTANT FOR ALL 112-T LIFTERS		
a	.828	Dimension between CL of Lifter Pocket to CL of Socket Screw
c	1.125	Pocket Diameter for Lifter Body + .001 / - .000
d	.875	Counter Bore Diameter for Lifter Washer
h	1.1245	Lifter Body Diameter + .0000 / - .0015
i	.188	Slot Height (for Stock) ± .005
j	.406	Dimension from Top of Slot to Top of Body ± .005
k	1.125	Length of Spring Pocket in Lifter Body
n	1.312	Dimension from Bottom of Washer (Slot) to Bottom of Body
p	.394	Counter Bore Depth for Washer & Socket Screw

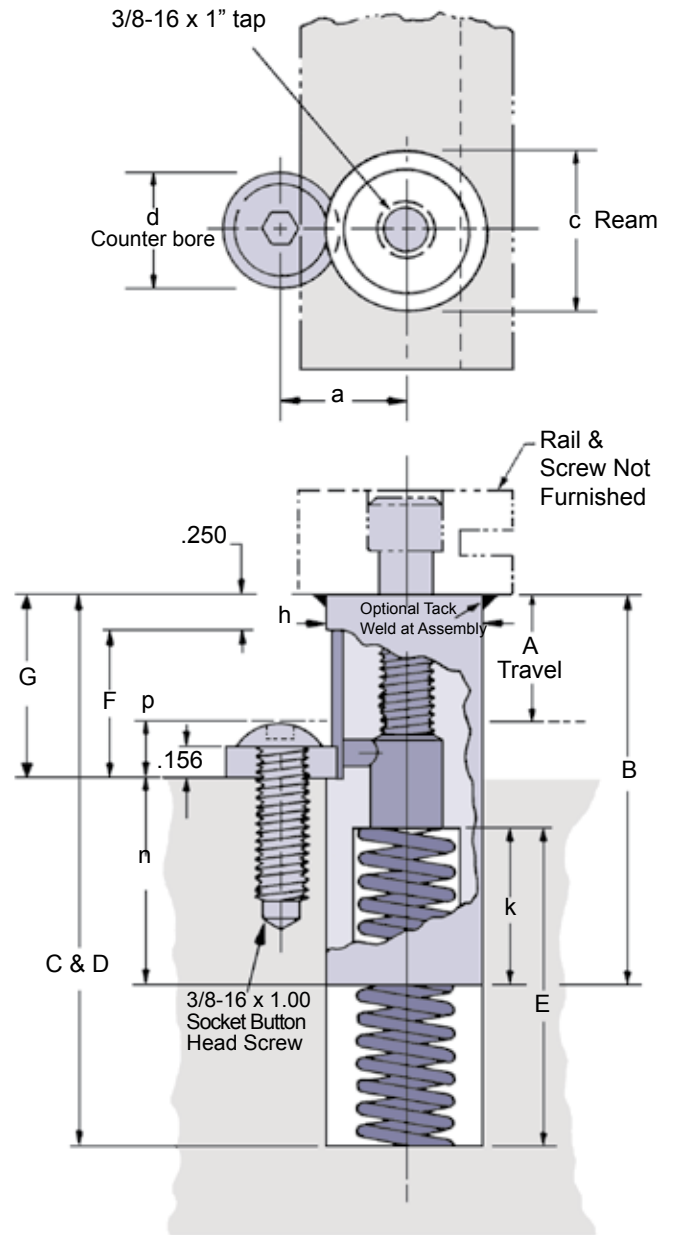

# Mini-Lifters

## Top or Side Mounted

3/8" and 1/2" diameters each to 3 different lengths. Hardened, ground and vented.

Accurately machined from solid bar steel and packaged complete with spring, socket head cap screw, dog point screw and retaining washer.

**Immediately available from Inventory.**

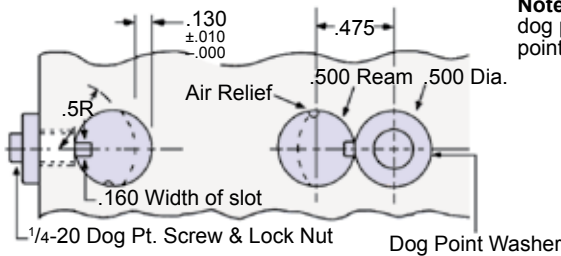
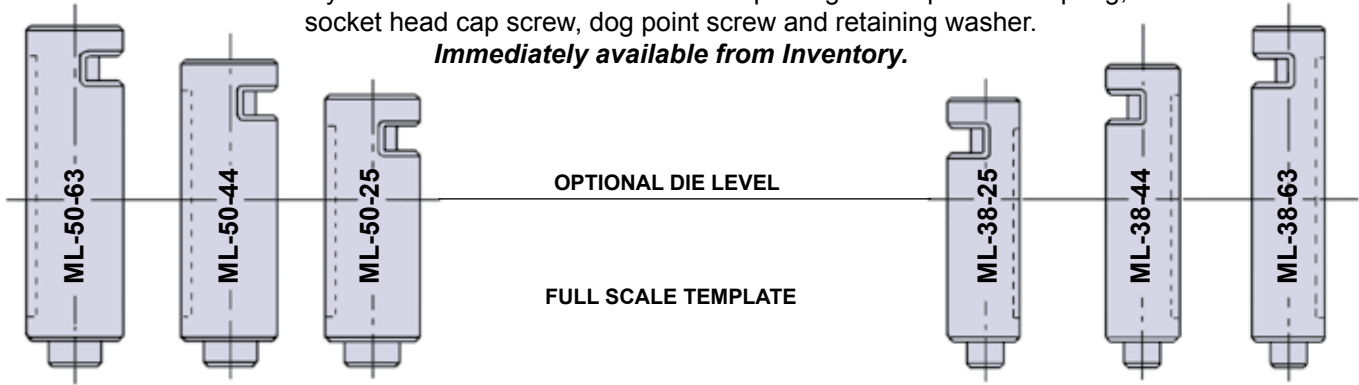

**Note:** Can be guided by dog point washer or dog point screw

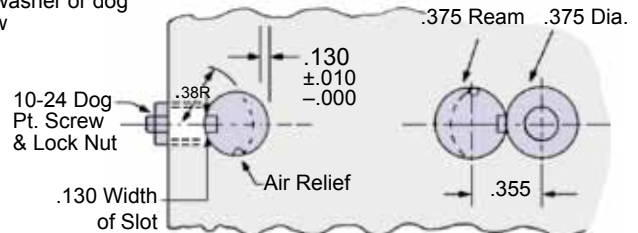

PART NUMBER	A TRAVEL	B LENGTH	C BORE LENGTH	D MIN.	E PRELOADED SPRINGS LENGTH	F SLOT LENGTH	REPLACEMENT DIE SPRING	SPRING FREE LENGTH	Lbs @ 1/10 SPRING DEFLECTIONS
<b>ML-50-25</b>	.25	1.28	2.13	2.30	1.38	0.990	M111L	1.50	6.8
<b>ML-50-44</b>	.44	1.47	2.63	2.80	1.88	1.180	M112L	2.00	5.5
<b>ML-50-63</b>	.63	1.66	3.13	3.30	2.38	1.370	M113L	2.50	4.5

PART NUMBER	A TRAVEL	B LENGTH	C BORE LENGTH	D MIN.	E PRELOADED SPRINGS LENGTH	F SLOT LENGTH	REPLACEMENT DIE SPRING	SPRING FREE LENGTH	Lbs @ 1/10 SPRING DEFLECTIONS
<b>ML-38-25</b>	.25	1.25	2.13	2.30	1.38	0.970	M101L	1.50	4.0
<b>ML-38-44</b>	.44	1.44	2.63	2.80	1.88	1.160	M102L	2.00	2.8
<b>ML-38-63</b>	.63	1.63	3.13	3.30	2.38	1.350	M103L	2.50	2.4

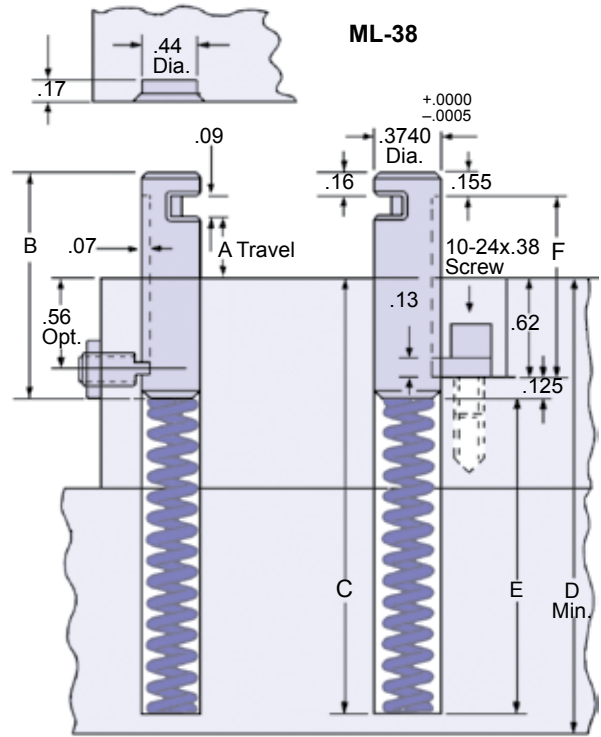
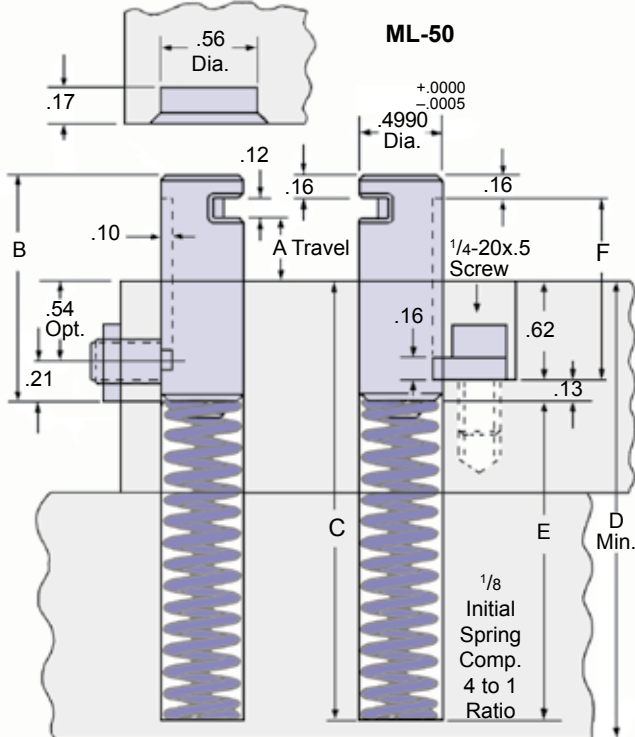



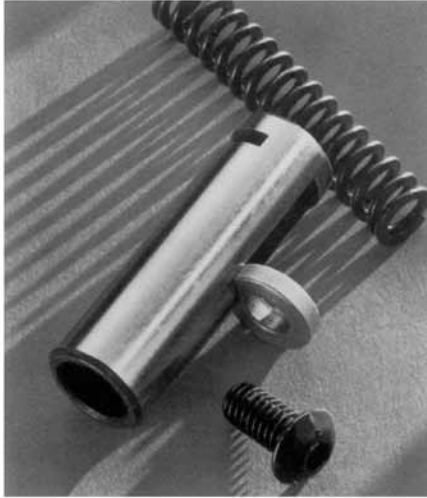

Design in (and build in) stock lifters just as easily as you do die springs and pins. Standard notched lifters are made in two sizes to handle stock up to .156" thick. Side center-rail lifters that easily accept your special rails are also offered.

These lifters all install from the top only. Easier to do and they can be replaced without taking the die from the press. All they need are two drilled holes, one tapped. Drop the spring and lifter in the larger one and secure them with the retaining screw in the tapped hole.

Go to standard lifters for consistent quality – they're all solid bar steel, hardened, ground and vented. You can't build them yourself for less.

REPLACEMENT PARTS				
PART NUMBER	REPLACEMENT SPRINGS	REPLACEMENT WASHERS	REPLACEMENT SCREWS	DIE LIFE KIT 6 SETS
75-50 T-750-50	M113L	75WASHER	75SCREW	DL75
75-75 T-750-75	M115L			
75-1-0 T-750-1-0	M115AL			
75-1-25 T-750-1-25	M115BL			
75-1-50 T-750-1-50	M115CL			
75-1-75 T-750-1-75	M115DL			
112-50 112T-50	M4L	112WASHER	112SCREW	DL112
112-75 112T-75	M6L			
112-1-0 112T-1-00	M8L			
112-1-25 112T-1-25	M10L			
112-1-50 112T-1-50	M11BL			
112-1-75 112T-1-75	M11CL			
ML-38-25 ML-38-44 ML-38-63	M101L M102L M103L	38WASHER	N/A	N/A
ML-50-25 ML-50-44 ML-50-63	M111L M112L M113L	50WASHER		

## Lifter Pins – Metric



Lifter pins are manufactured from 1144 steel and are commonly used to handle large die sets. They conform to NAAMS standards.

The internal spring provides added assurance that the fall ring will function properly during the course of the pin's use.

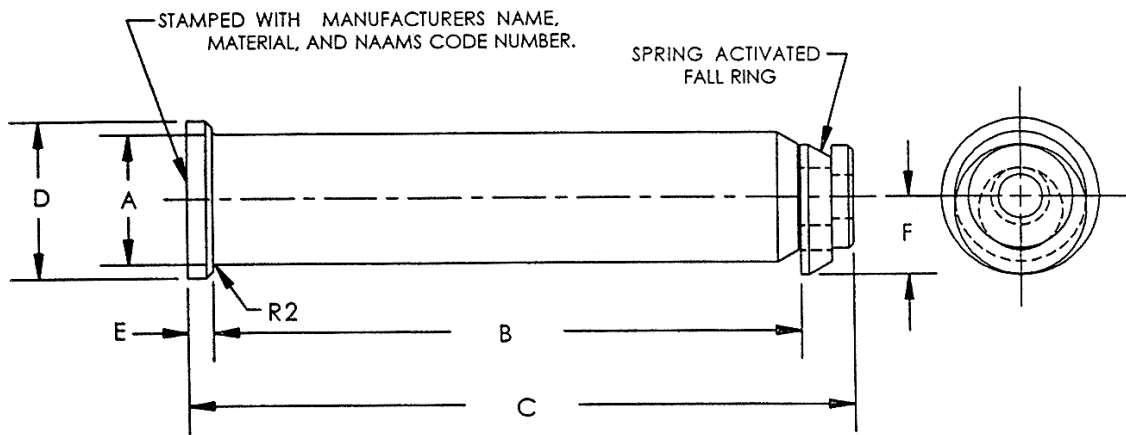

PART NUMBER	NAAMS Code	A (mm)	B (mm)	C (mm)	D (mm)	E (mm)	F (mm)	Total Die Wt. in Metric Tons (t)
LP35-125	L013512	35	125	165	45	10	21.5	0 – 2.72
LP50-190	L015019	50	190	230	63	10	31	2.72 – 9.07
LP63-280	L016328	63	280	320	76	10	37.5	9.07 – 36.28
LP80-320	L018032	80	320	370	89	15	46	36.28 – 72.57

## Stop Blocks



These stop blocks are precision machined from 1018 material. Additionally, the blocks are inspected to provide uniform quality and dimensions. The length dimension is .060" oversize.

FOR 1/2" SOC. HD.  
CAP SCREW OR M12

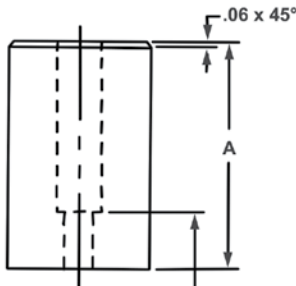
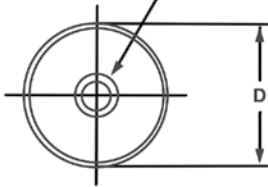

.50 WHEN "A" = 2.00 & LESS  
1.38 WHEN "A" = 2.50

PART NUMBER	Diameter D (in)	Length A (in)
20-150CSB	2.00	1.50
20-200CSB		2.00
20-250CSB		2.50
20-300CSB		3.00
20-350CSB		3.50
20-400CSB		4.00
20-425CSB		4.25
20-475CSB		4.75
20-525CSB		5.25
20-550CSB		5.50
20-600CSB		6.00
20-650CSB		6.50
25-150CSB	2.50	1.50
25-200CSB		2.00
25-250CSB		2.50
25-300CSB		3.00
25-350CSB		3.50
25-400CSB		4.00
25-425CSB		4.25
25-475CSB		4.75
25-525CSB		5.25
25-550CSB		5.50
25-600CSB		6.00
25-650CSB		6.50

# Pad Retainers – Locking Inch, Standard Mount



\*Formerly Part Number PRL\_\_\_\_\_

Pad retainers are manufactured from 1144 steel and hardened to 28-34 Rockwell C-scale. They are machined to precise tolerances in order to retain the pad and assure parallelism during use.

The NP Series is also available, by special order, that offers three prongs as opposed to knurl.

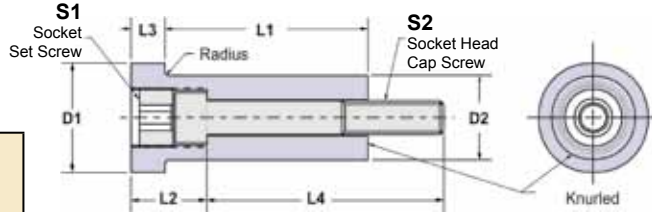

PART NUMBER	Diam. D1 (in)	Diam. ± .005 D2 (in)	Length L1 (in)	L2 (in)	L3 (in)	L4 (in)	S1 (in)	S2 (in)
100-100	1.00	.75	1.00	1.00	.38	1.00	5/8 - 18	5/16 - 18
100-125			1.25			1.25		
100-150			1.50			1.50		
100-175			1.75			1.75		
100-200			2.00			2.00		
100-225			2.25			2.25		
100-250			2.50			2.50		
100-275			2.75			2.75		
100-300			3.00			3.00		
100-325			3.25			3.25		
100-350	3.50	3.50						
106-100	1.06	.81	1.00	1.00	.375	1.00	5/8 - 18	5/16 - 18
106-125			1.25			1.25		
106-150			1.50			1.50		
106-175			1.75			1.75		
106-200			2.00			2.00		
106-225			2.25			2.25		
106-250			2.50			2.50		
106-275			2.75			2.75		
106-300			3.00			3.00		
106-325			3.25			3.25		
106-350	3.50	3.50						
125-100	1.25	1.00	1.00	1.12	.50	1.00	3/4 - 16	3/8 - 16
125-125			1.25			1.25		
125-150			1.50			1.50		
125-175			1.75			1.75		
125-200			2.00			2.00		
125-225			2.25			2.25		
125-250			2.50			2.50		
125-275			2.75			2.75		
125-300			3.00			3.00		
125-325			3.25			3.25		
125-350	3.50	3.50						
125-375	3.75	3.75						
125-400	4.00	4.00						
125-450	4.50	4.50						
125-500	5.00	5.00						
125-550	5.50	5.50						
125-600	6.00	6.00						
162-100	1.62	1.25	1.00	1.12	.50	1.25	7/8 - 14	1/2 - 13
162-125			1.25			1.50		
162-150			1.50			1.75		
162-175			1.75			2.00		
162-200			2.00			2.25		
162-225			2.25			2.50		
162-250			2.50			2.75		
162-275			2.75			3.00		
162-300			3.00			3.25		
162-325			3.25			3.50		
162-350	3.50	3.75						
162-375	3.75	4.00						
162-400	4.00	4.50						
162-450	4.50	5.00						
162-500	5.00	5.50						
162-550	5.50	6.00						
162-600	6.00	6.50						
200-150	2.00	1.62	1.50	1.38	.50	1.50	1-1/4 - 12	3/4 - 10
200-175			1.75			2.00		
200-200			2.00			2.25		
200-225			2.25			2.50		
200-250			2.50			2.75		
200-275			2.75			3.00		
200-300			3.00			3.25		
200-325			3.25			3.50		
200-350			3.50			3.75		
200-375			3.75			4.00		
200-400	4.00	4.50						
200-450	4.50	5.00						
200-500	5.00	5.50						
200-550	5.50	6.00						
200-600	6.00	6.50						

### ASSEMBLY INCLUDES:

- Retainer Body
- Socket Head Cap Screws
- Socket Set Screw

PART NO.	RADIUS (in)	LOAD RATING lbs.
100-XXX	0.03	1,500
106-XXX	0.03	1,500
125-XXX	0.03	3,000
162-XXX	0.06	5,000
187-XXX	0.06	7,500
200-XXX	0.06	10,000

PART NUMBER	Diam. D1 (in)	Diam. ± .005 D2 (in)	Length L1 (in)	L2 (in)	L3 (in)	L4 (in)	S1 (in)	S2 (in)						
162-400	1.62	1.25	4.00	1.12	.50	4.25	7/8 - 14	1/2 - 13						
162-450			4.50			4.75								
162-500			5.00			5.25								
162-550			5.50			6.00								
162-600			6.00			6.50								
187-125			1.87			1.50			1.25	1.25	.50	1.50	1-1/8 - 12	5/8 - 11
187-150									1.50			1.75		
187-175									1.75			2.00		
187-200									2.00			2.25		
187-225									2.25			2.50		
187-250	2.50	2.75												
187-275	2.75	3.00												
187-300	3.00	3.25												
187-325	3.25	3.50												
187-350	3.50	3.75												
187-375	3.75	4.00												
187-400	4.00	4.25												
187-450	4.50	5.00												
187-500	5.00	5.50												
187-550	5.50	6.00												
187-600	6.00	6.50												
200-150	2.00	1.62	1.50	1.38	.50	2.00	1-1/4 - 12	3/4 - 10						
200-175			1.75			2.25								
200-200			2.00			2.50								
200-225			2.25			2.75								
200-250			2.50			3.00								
200-275			2.75			3.25								
200-300			3.00			3.50								
200-325			3.25			3.75								
200-350			3.50			4.00								
200-375			3.75			4.25								
200-400	4.00	4.50												
200-450	4.50	5.00												
200-500	5.00	5.50												
200-550	5.50	6.00												
200-600	6.00	6.50												

# Pad Retainers – Locking Inch, Standard Mount, with Flats



\*Formerly Part Number PRLF\_\_\_

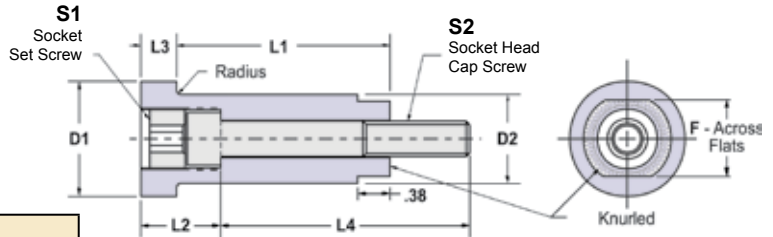

PART NUMBER	Diam. D1 (in)	Diam. ± .005 D2 (in)	Length L1 (in)	L2 (in)	L3 (in)	L4 (in)	S1 (in)	S2 (in)
100-100F	1.00	.75	1.00	1.00	.38	1.00	5/8 - 18	5/16 - 18
100-125F			1.25			1.25		
100-150F			1.50			1.50		
100-175F			1.75			1.75		
100-200F			2.00			2.00		
100-225F			2.25			2.25		
100-250F			2.50			2.50		
100-275F			2.75			2.75		
100-300F			3.00			3.00		
100-325F			3.25			3.25		
100-350F			3.50			3.50		
106-100F	1.06	.81	1.00	1.00	.38	1.00	5/8 - 18	5/16 - 18
106-125F			1.25			1.25		
106-150F			1.50			1.50		
106-175F			1.75			1.75		
106-200F			2.00			2.00		
106-225F			2.25			2.25		
106-250F			2.50			2.50		
106-275F			2.75			2.75		
106-300F			3.00			3.00		
106-325F			3.25			3.25		
106-350F			3.50			3.50		
125-100F	1.25	1.00	1.00	1.12	.50	1.00	3/4 - 16	3/8 - 16
125-125F			1.25			1.25		
125-150F			1.50			1.50		
125-175F			1.75			1.75		
125-200F			2.00			2.00		
125-225F			2.25			2.25		
125-250F			2.50			2.50		
125-275F			2.75			2.75		
125-300F			3.00			3.00		
125-325F			3.25			3.25		
125-350F			3.50			3.50		
125-375F	3.75	3.75						
125-400F	4.00	4.00						
125-450F	4.50	4.50						
125-500F	5.00	5.00						
125-550F	5.50	5.50						
125-600F	6.00	6.00						
162-100F	1.62	1.25	1.00	1.12	.50	1.25	7/8 - 14	1/2 - 13
162-125F			1.25			1.50		
162-150F			1.50			1.75		
162-175F			1.75			2.00		
162-200F			2.00			2.25		
162-225F			2.25			2.50		
162-250F			2.50			2.75		
162-275F			2.75			3.00		
162-300F			3.00			3.25		
162-325F			3.25			3.50		
162-350F			3.50			3.75		
162-375F	3.75	4.00						
162-400F	4.00	4.25						
162-450F	4.50	5.00						
162-500F	5.00	5.50						
162-550F	5.50	6.00						
162-600F	6.00	6.50						

### ASSEMBLY INCLUDES:

- Retainer Body
- Socket Head Cap Screws
- Socket Set Screw

PART NO.	F (in)	RADIUS (in)	LOAD RATING lbs.
100-XXX	.625	0.03	1,500
106-XXX	.690	0.03	1,500
125-XXX	.875	0.03	3,000
162-XXX	1.125	0.06	5,000
187-XXX	1.250	0.06	7,500
200-XXX	1.375	0.06	10,000

PART NUMBER	Diam. D1 (in)	Diam. ± .005 D2 (in)	Length L1 (in)	L2 (in)	L3 (in)	L4 (in)	S1 (in)	S2 (in)						
162-400F	1.62	1.25	4.00	1.12	.50	4.25	7/8 - 14	1/2 - 13						
162-450F			4.50			4.75								
162-500F			5.00			5.25								
162-550F			5.50			6.00								
162-600F			6.00			6.50								
187-125F			1.87			1.50			1.25	1.25	0.50	1.50	1-1/8 - 12	5/8 - 11
187-150F									1.50			1.75		
187-175F									1.75			2.00		
187-200F									2.00			2.25		
187-225F									2.25			2.50		
187-250F									2.50			2.75		
187-275F	2.75	3.00												
187-300F	3.00	3.25												
187-325F	3.25	3.50												
187-350F	3.50	3.75												
187-375F	3.75	4.00												
187-400F	4.00	4.25												
187-450F	4.50	5.00												
187-500F	5.00	5.50												
187-550F	5.50	6.00												
187-600F	6.00	6.50												
200-150F	2.00	1.62	1.50	1.38	0.50	2.00	1-1/4 - 12	3/4 - N10						
200-175F			1.75			2.25								
200-200F			2.00			2.50								
200-225F			2.25			2.75								
200-250F			2.50			3.00								
200-275F			2.75			3.25								
200-300F			3.00			3.50								
200-325F			3.25			3.75								
200-350F			3.50			4.00								
200-375F			3.75			4.25								
200-400F			4.00			4.50								
200-450F	4.50	5.00												
200-500F	5.00	5.50												
200-550F	5.50	6.00												
200-600F	6.00	6.50												

## Pad Retainers – Locking Inch, Reverse Mount, with Flats

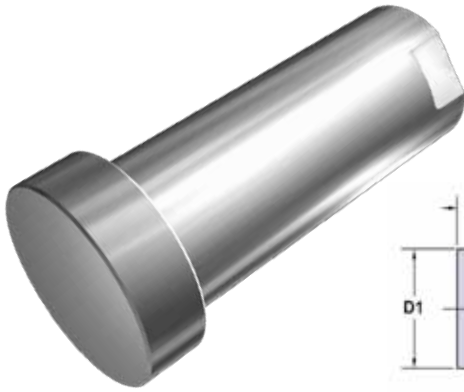

Pad retainers are manufactured from 1144 steel and hardened to 28-34 Rockwell C-scale. They are machined to precise tolerances in order to retain the pad and assure parallelism during use.

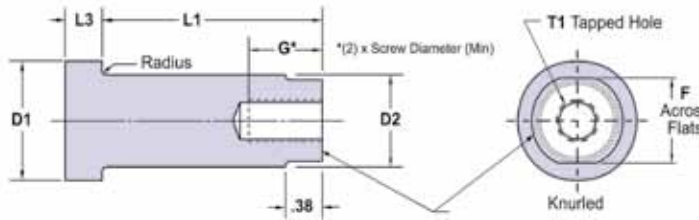

\*Formerly Part Number PRRF \_\_\_\_

PART NO.	F (in)	RADIUS (in)	LOAD RATING lbs.
100-XXXR	.625	0.03	1,500
106-XXXR	.690	0.03	1,500
125-XXXR	.875	0.03	3,000
162-XXXR	1.125	0.06	5,000
187-XXXR	1.250	0.06	7,500
200-XXXR	1.375	0.06	10,000

PART NUMBER	Diam. D1 (in)	Diam. ± .005 D2 (in)	Length L1 (in)	G (in)	L3 (in)	T1 (in)
100-100R	1.00	.75	1.00	.625	.38	5/16 - 18
100-125R			1.25			
100-150R			1.50			
100-175R			1.75			
100-200R			2.00			
100-225R			2.25			
100-250R			2.50			
100-275R			2.75			
100-300R			3.00			
100-350R			3.50			
100-375R			3.75			
100-400R			4.00			
100-450R			4.50			
100-500R			5.00			
100-550R			5.50			
100-600R			6.00			
106-100R	1.06	.81	1.00	.625	.38	5/16 - 18
106-125R			1.25			
106-150R			1.50			
106-175R			1.75			
106-200R			2.00			
106-225R			2.25			
106-250R			2.50			
106-275R			2.75			
106-300R			3.00			
106-325R			3.25			
106-350R	3.50					
125-100R	1.25	1.00	1.00	.750	.50	3/8 - 16
125-125R			1.25			
125-150R			1.50			
125-175R			1.75			
125-200R			2.00			
125-225R			2.25			
125-250R			2.50			
125-275R			2.75			
125-300R			3.00			
125-325R			3.25			
125-350R			3.50			
125-375R			3.75			
125-400R			4.00			
125-450R			4.50			
125-500R			5.00			
125-550R			5.50			
125-600R	6.00					

PART NUMBER	Diam. D1 (in)	Diam. ± .005 D2 (in)	Length L1 (in)	G (in)	L3 (in)	T1 (in)
162-125R	1.62	1.25	1.25	1.000	.50	1/2 - 13
162-150R			1.50			
162-175R			1.75			
162-200R			2.00			
162-225R			2.25			
162-250R			2.50			
162-275R			2.75			
162-300R			3.00			
162-325R			3.25			
162-350R			3.50			
162-375R			3.75			
162-400R			4.00			
162-450R			4.50			
162-500R			5.00			
162-550R			5.50			
162-600R			6.00			
187-150R	1.87	1.50	1.50	1.250	.50	5/8 - 11
187-175R			1.75			
187-200R			2.00			
187-225R			2.25			
187-250R			2.50			
187-275R			2.75			
187-300R			3.00			
187-325R			3.25			
187-350R			3.50			
187-375R			3.75			
187-400R	4.00					
187-450R	4.50					
187-500R	5.00					
187-550R	5.50					
187-600R	6.00					
200-175R	2.00	1.62	1.75	1.500	.50	3/4 - 10
200-200R			2.00			
200-225R			2.25			
200-250R			2.50			
200-275R			2.75			
200-300R			3.00			
200-325R			3.25			
200-350R			3.50			
200-375R			3.75			
200-400R			4.00			
200-450R			4.50			
200-500R			5.00			
200-550R			5.50			
200-600R			6.00			

## Pad Retainers – Standard And Reverse Mount – Metric



**STANDARD MOUNT**

Pad retainers are manufactured from 1144 steel and hardened to 28-34 Rockwell C-scale. They are machined to precise tolerances in order to retain the pad and assure parallelism during use.



**REVERSE MOUNT**

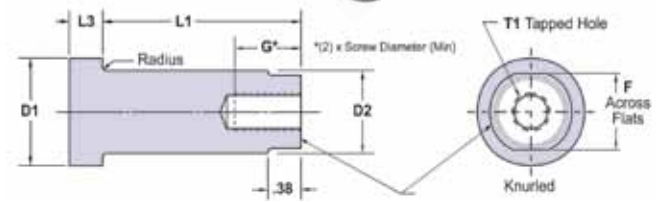
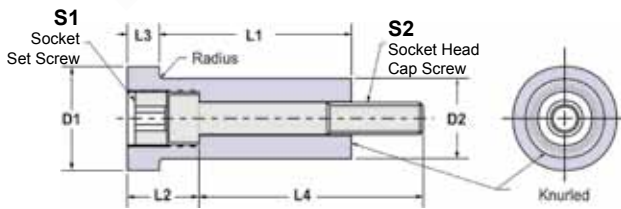

PART NUMBER	D1	D2	L2	L3	S1	S2	LOAD RATING
NR50	50	40	35	15	M27 X 2	M16 X 2.0	192 kN
NR70	70	60	40	15	M36 X 3	M20 X 2.5	299kN

PART NUMBER	D1	D2	L3	F	LOAD RATING
NR50	50	40	15	33.65	192 kN
NR70	70	60	15	53.70	299kN

PART NUMBER	Diameter D2 (mm)	Length L1 (mm)	Diameter D1 (mm)		
NR50-30	40	30	50		
NR50-40		40			
NR50-45		45			
NR50-50		50			
NR50-60		60			
NR50-65		65			
NR50-70		70			
NR50-75		75			
NR50-90		90			
NR50-100		100			
NR50-115		115			
NR50-130		130			
NR50-140		140			
NR50-160		160			
NR70-40		60		40	70
NR70-45				45	
NR70-50	50				
NR70-60	60				
NR70-65	65				
NR70-70	70				
NR70-75	75				
NR70-90	90				
NR70-100	100				
NR70-115	115				
NR70-130	130				
NR70-140	140				
NR70-160	160				

PART NUMBER	Diameter D2 (mm)	Length L1 (mm)	Diameter D1 (mm)		
NR50-30R	40	30	50		
NR50-40R		40			
NR50-45R		45			
NR50-50R		50			
NR50-60R		60			
NR50-65R		65			
NR50-70R		70			
NR50-75R		75			
NR50-90R		90			
NR50-100R		100			
NR50-115R		115			
NR50-130R		130			
NR50-140R		140			
NR50-160R		160			
NR70-40R		60		40	70
NR70-45R				45	
NR70-50R	50				
NR70-60R	60				
NR70-65R	65				
NR70-70R	70				
NR70-75R	75				
NR70-90R	90				
NR70-100R	100				
NR70-115R	115				
NR70-130R	130				
NR70-140R	140				
NR70-160R	160				

## Commitment to Quality & Customer Satisfaction

*Dayton Lamina is a leading manufacturer of tool, die and mold components for the metal-working and plastics industries. As a customer-focused, world-class supplier of choice, we provide the brands, product breadth, distribution network and technical support for all your metal forming needs.*

*Our goal is to give our customers the most innovative and value-added products and services.*



# DAYTON Lamina™

a MISUMI Group Company



Lamina® LEMPCO

\*Dayton Lamina's line of Danly products is available only to North America.

[www.daytonlamina.com](http://www.daytonlamina.com)